

VERDI

FR NOTICE D'INSTALLATION, UTILISATION ET ENTRETIEN

EN INSTALLATION, USE AND MAINTENANCE MANUAL

DE AUFBAU-, GEBRAUCHS- UND WARTUNGSANLEITUNG

NL HANDLEIDING VOOR INSTALLATIE, GEBRUIK EN ONDERHOUD

FR Outils et matériel nécessaires au montage (non fourni).
EN Tools and materials required for installation (not supplied).
DE Für die Montage benötigte Werkzeuge und Hilfsmittel (nicht mitgeliefert).
NL Benodigde gereedschappen en materialen voor de installatie (niet meegeleverd).

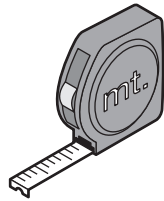
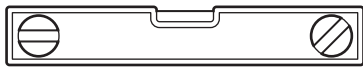

SCOTCH

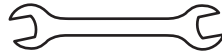

TEFLON

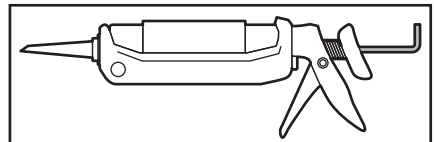
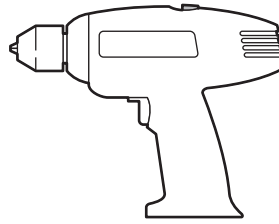

FR Non acétique
EN Acetic-acid free
DE Nicht essigsäurevernetzend
NL Niet zuur

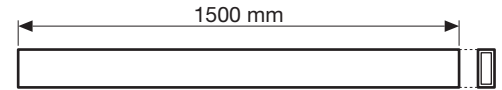
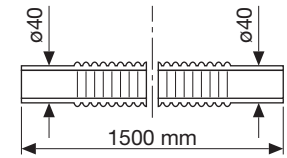

FR - CARACTERISTIQUES TECHNIQUES

CARACTERISTIQUES HYDRAULIQUES:
 Pression dynamique optimale 2:5 bar
 Eau chaude 1/2"
 Eau froide 1/2"
 Branchement siphon avec raccord ø40 mm

EN - TECHNICAL SPECIFICATIONS

HYDRAULIC CHARACTERISTICS:
 Working pressure 2:5 bar
 Hot water 1/2"
 Cold water 1/2"
 Syphon connection ø40 mm

DE - TECHNISCHE EIGENSCHAFTEN

HYDRAULISCHE EIGENSCHAFTEN:
 Optimaler dynamischer Druck 2+5 bar
 Warmwasser 1/2"
 Kaltwasser 1/2"
 Siphonanschluss ø40 mm

NL - TECHNISCHE KENMERKEN

HYDRAULISCHE GEGEVENS:
 Optimale waterdruk 2-5 bar
 Warm water 1/2"
 Koud water 1/2"
 Sifonaansluiting ø 40 mm

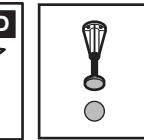
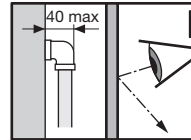
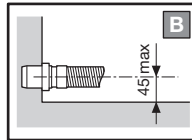
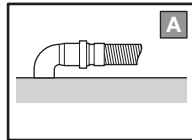

mod. R90 p.80

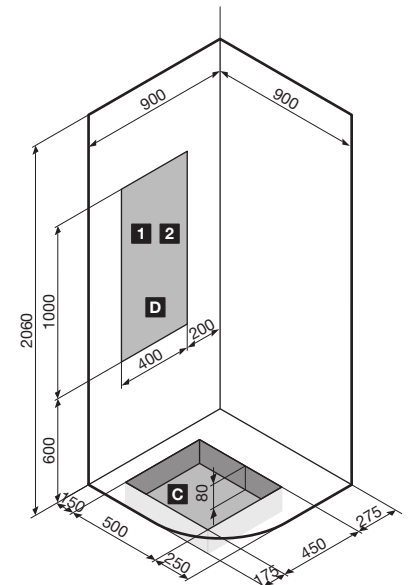
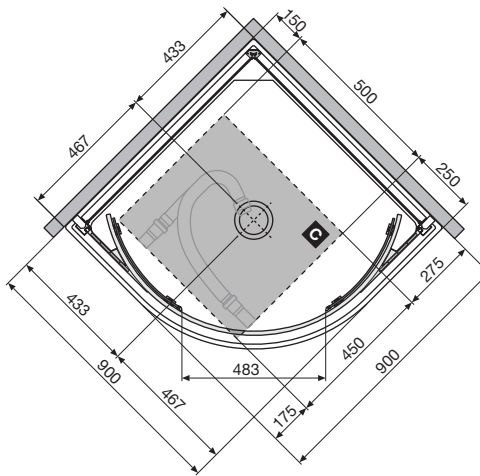
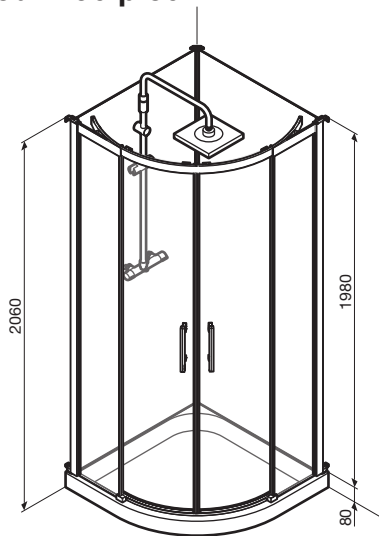

mod. R90 p.150

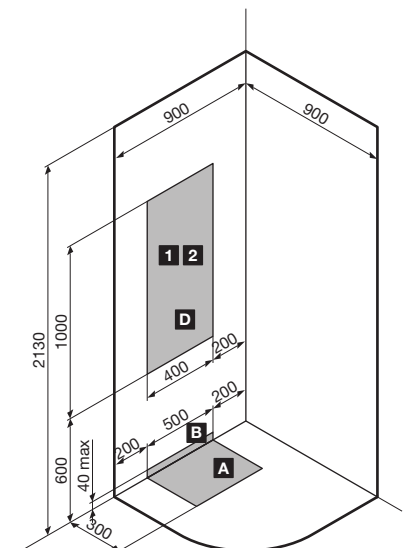
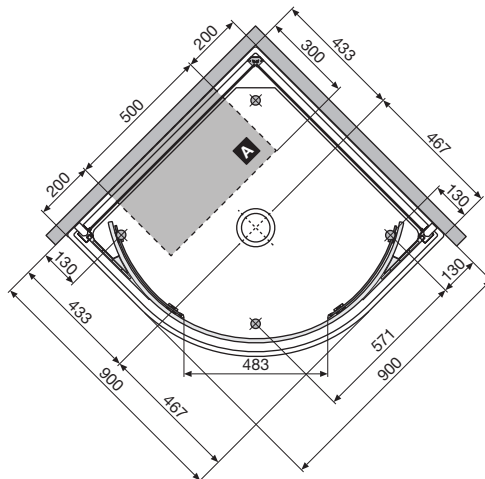
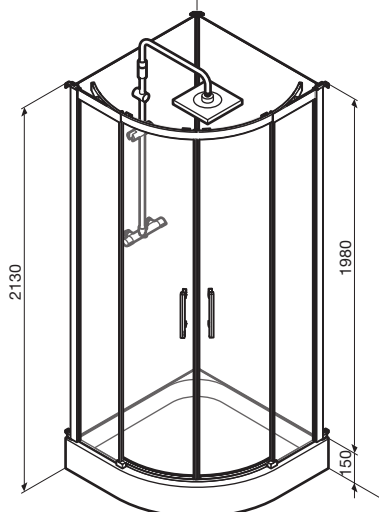

mod. GF90 p.80

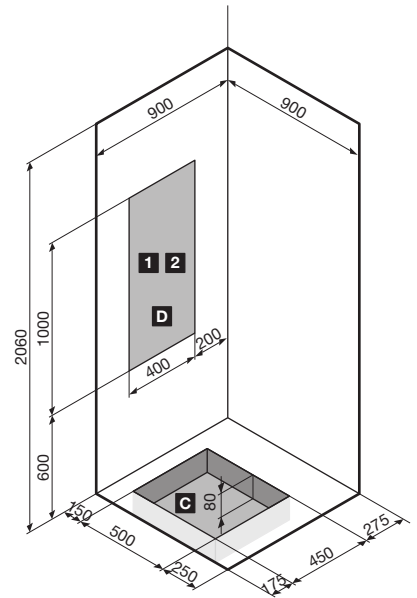
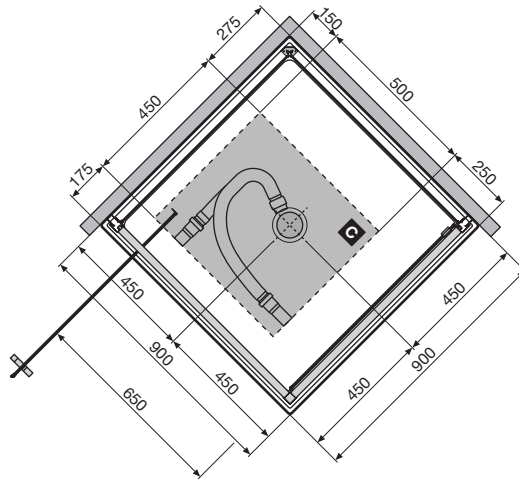
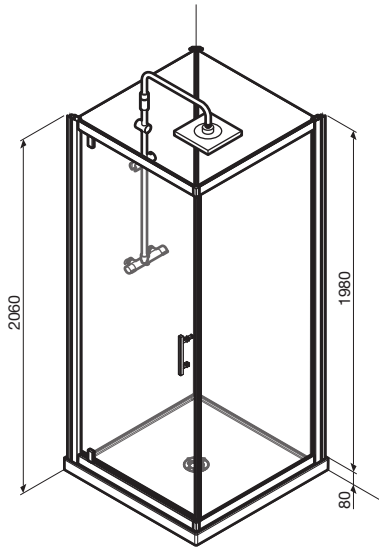

mod. 2P 120x80 dx p.80

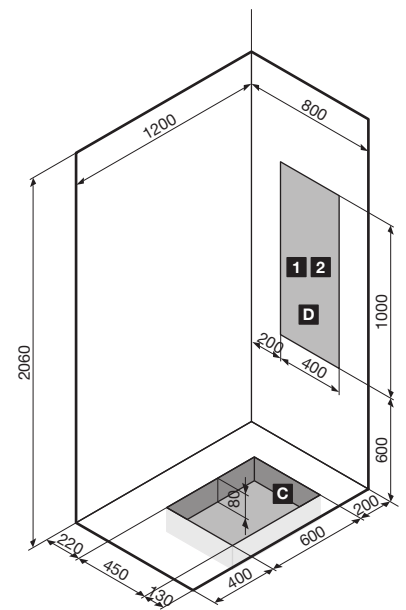
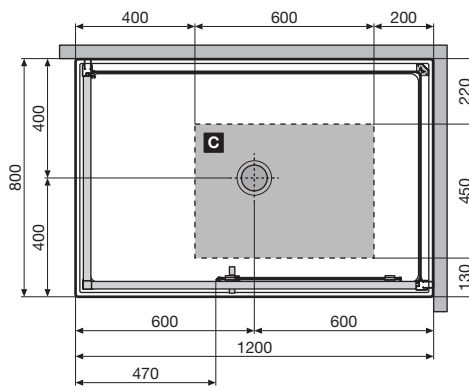
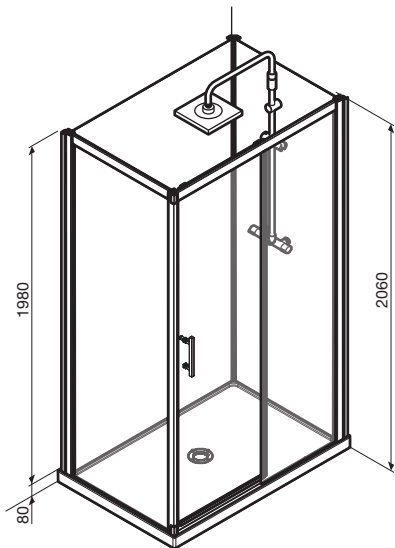

mod. 2P 120x80 sx p.80

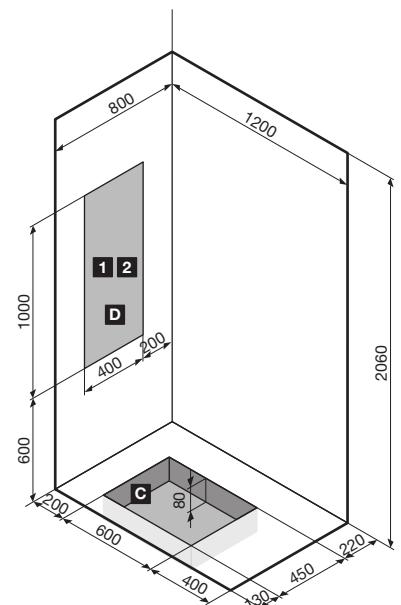
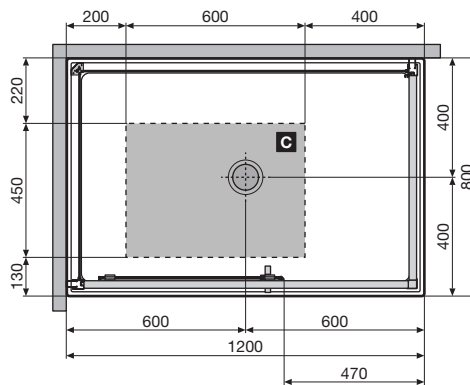
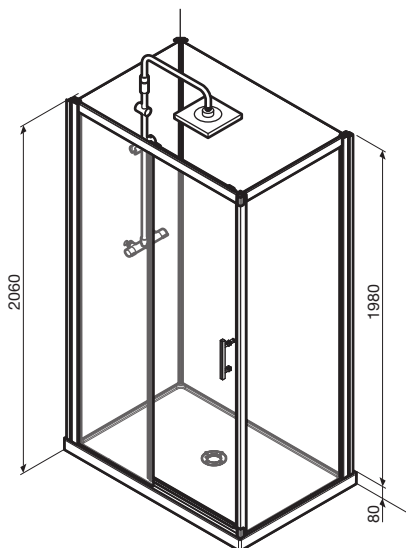

mod. A90 p.80

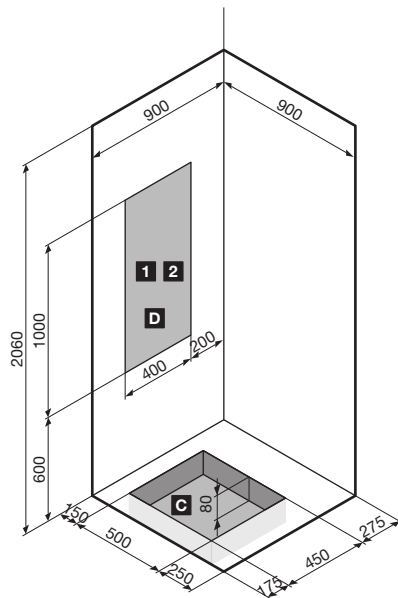
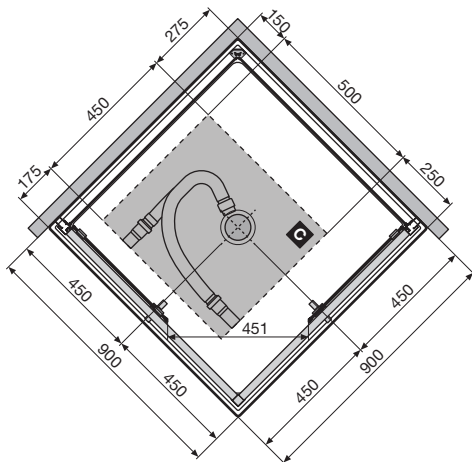
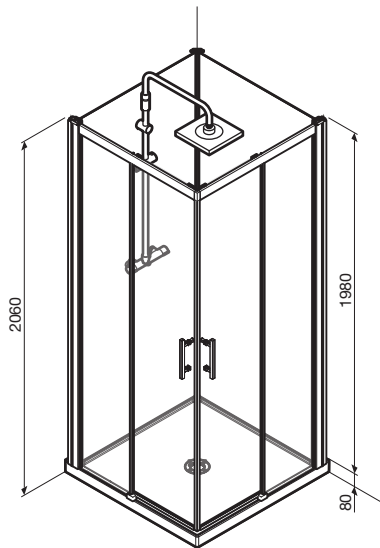

mod. 2P 120x90 dx p.80

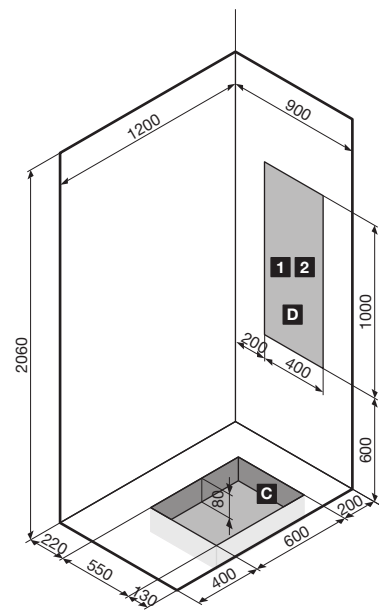
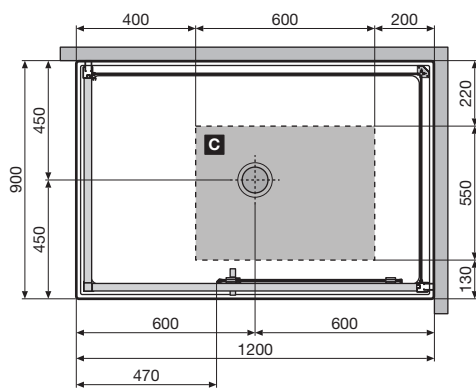
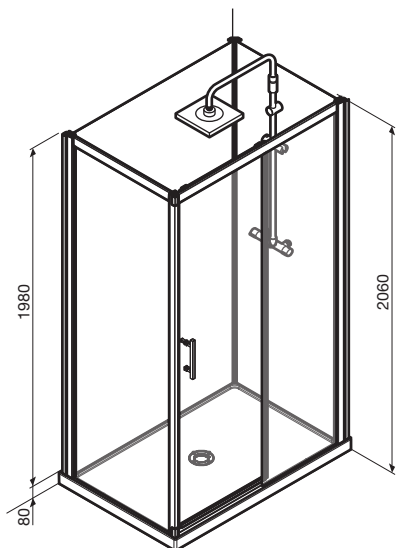

mod. 2P 120x90 sx p.80

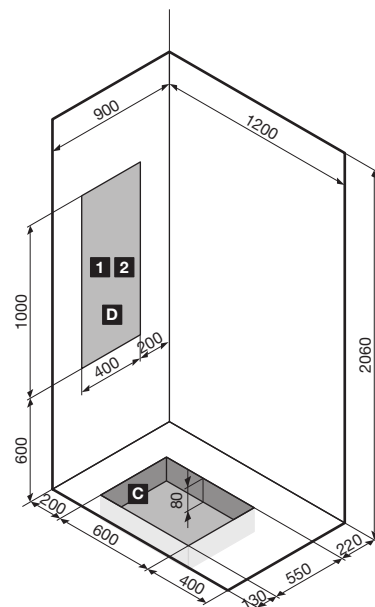
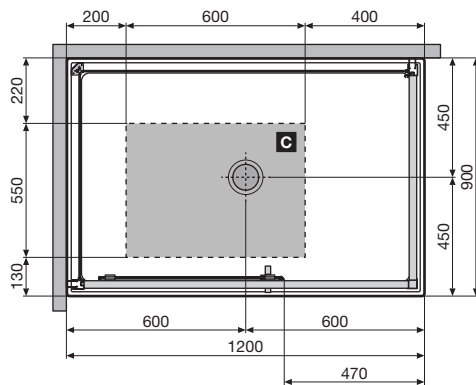
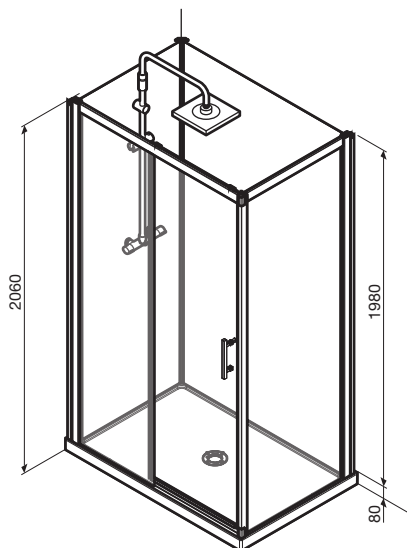

mod. GF90 p.150

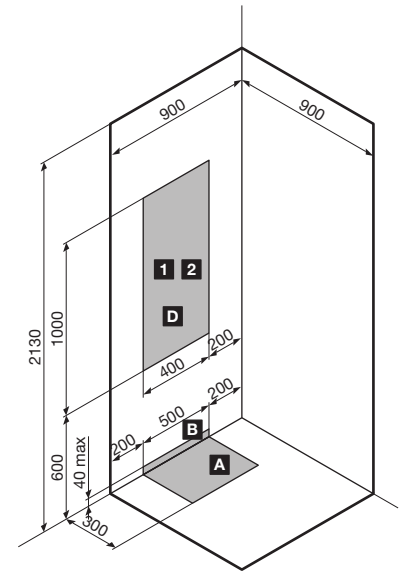
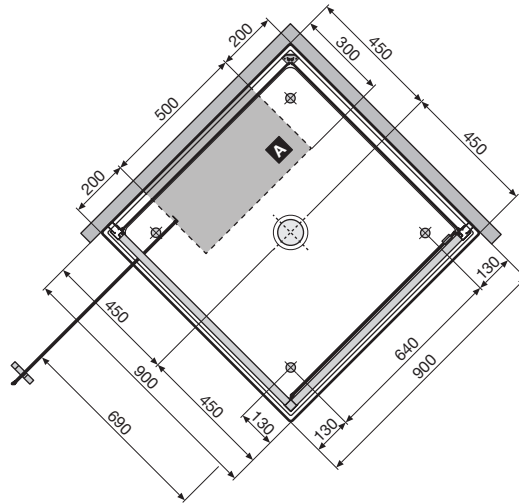
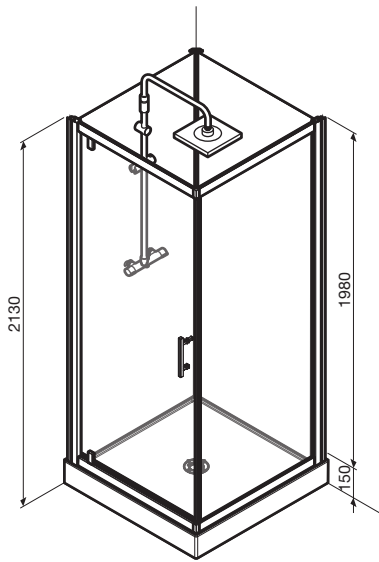

mod. 2P 120x80 dx p.150

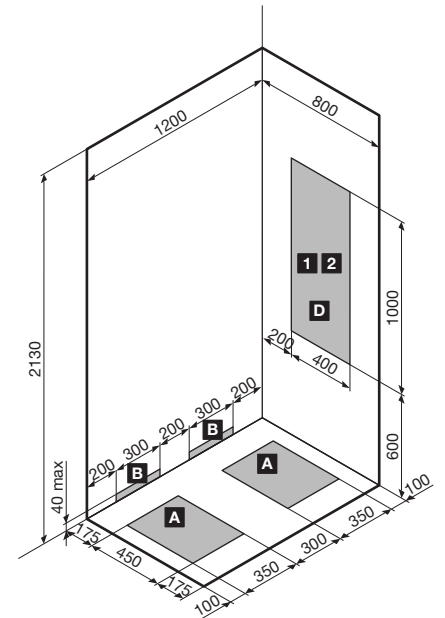
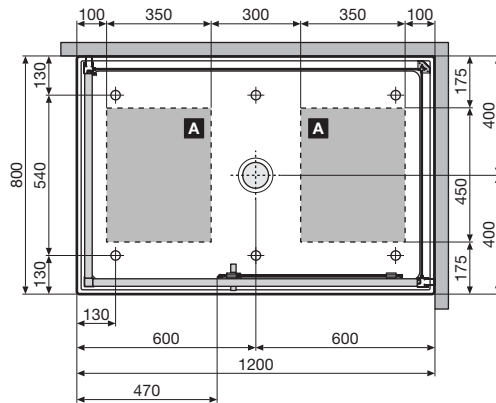
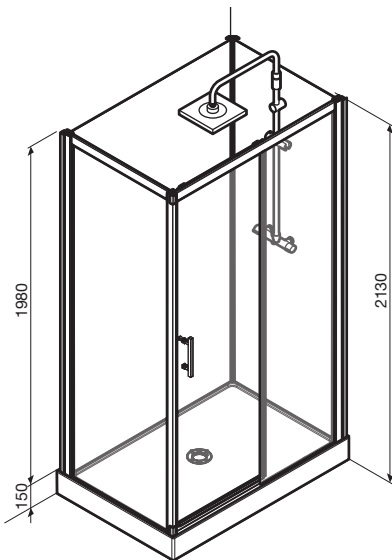

mod. 2P 120x80 sx p.150

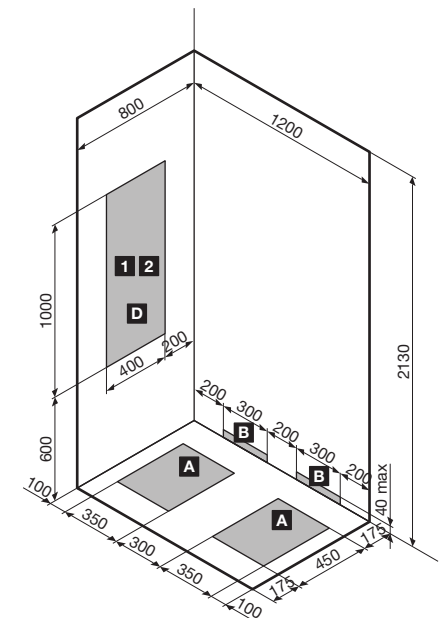
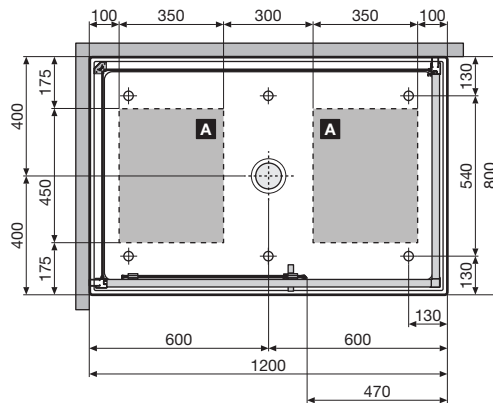
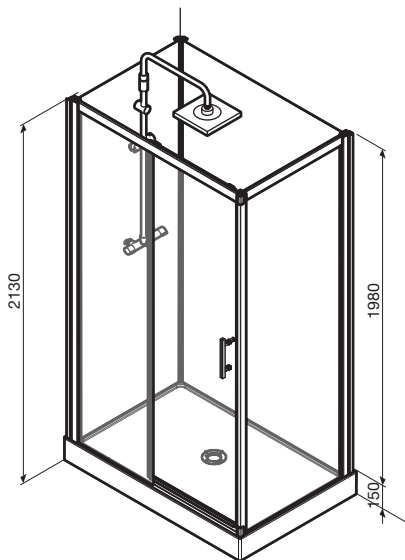

mod. A90 p.150

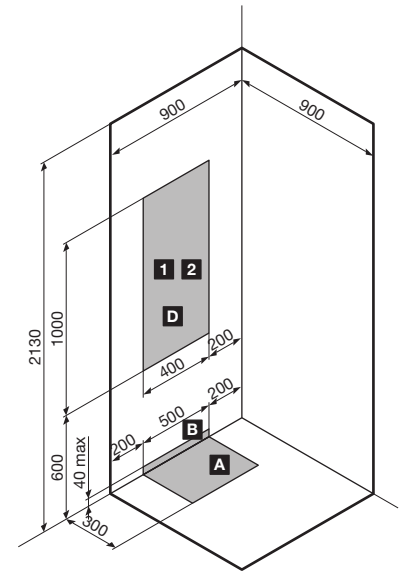
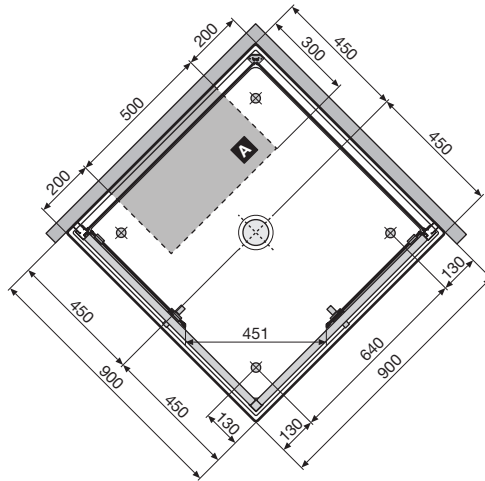
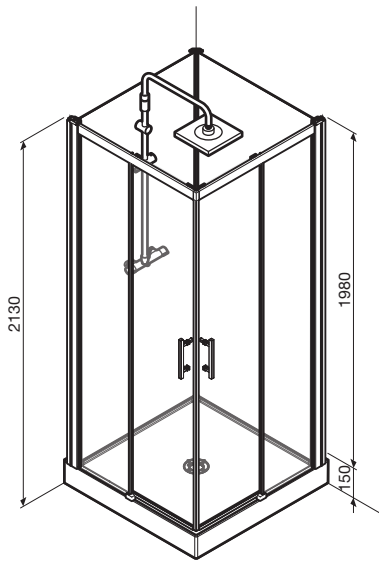

mod. 2P 120x90 dx p.150

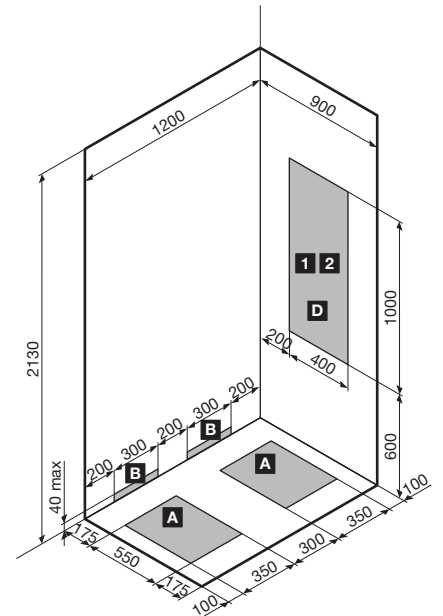
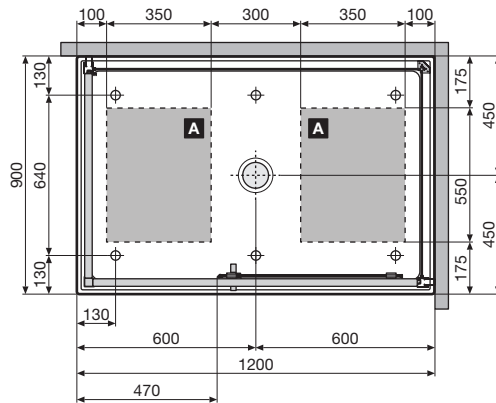
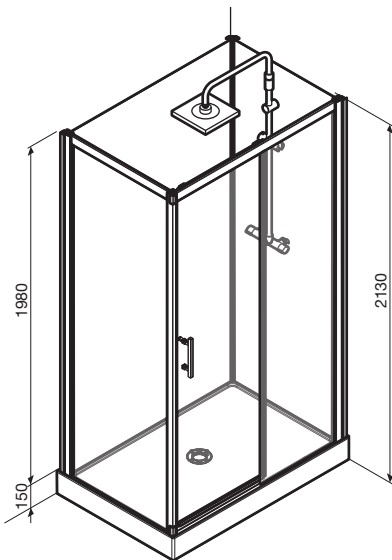

mod. 2P 120x90 sx p.150

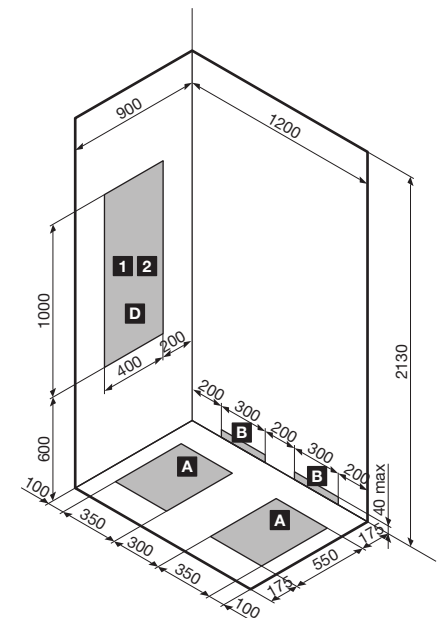
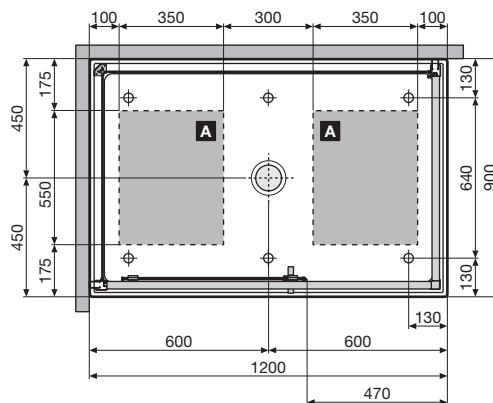
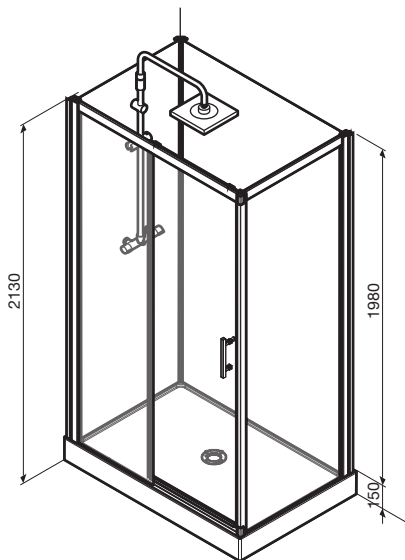

IA

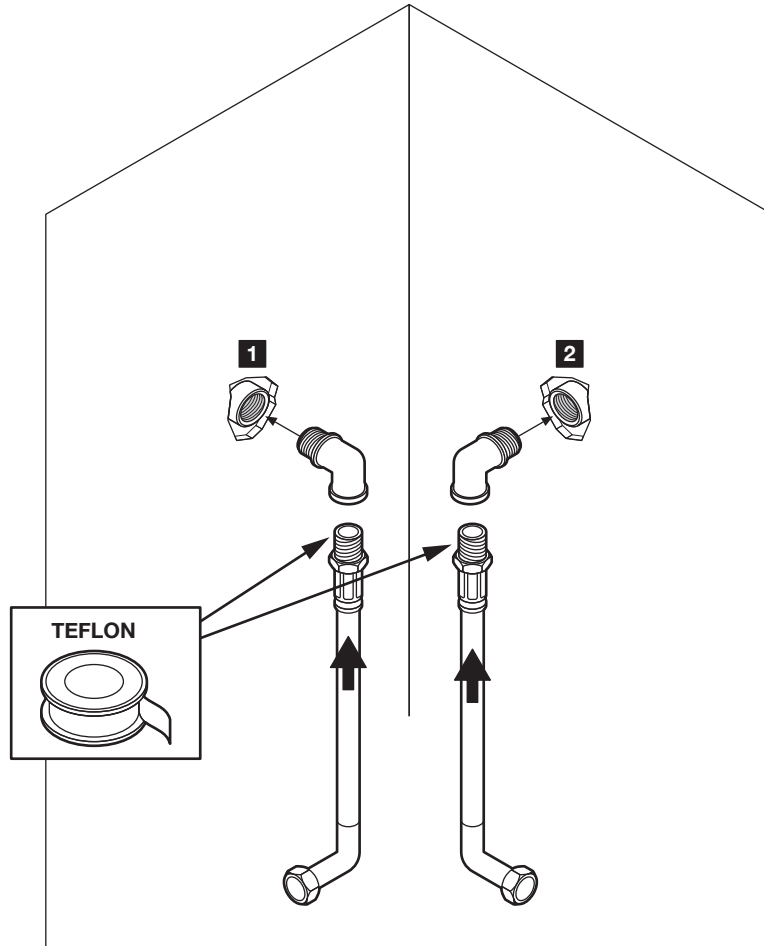
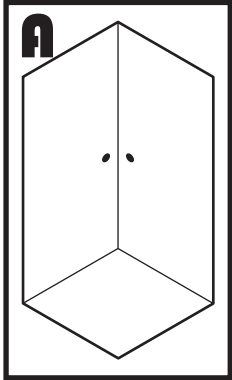

IB

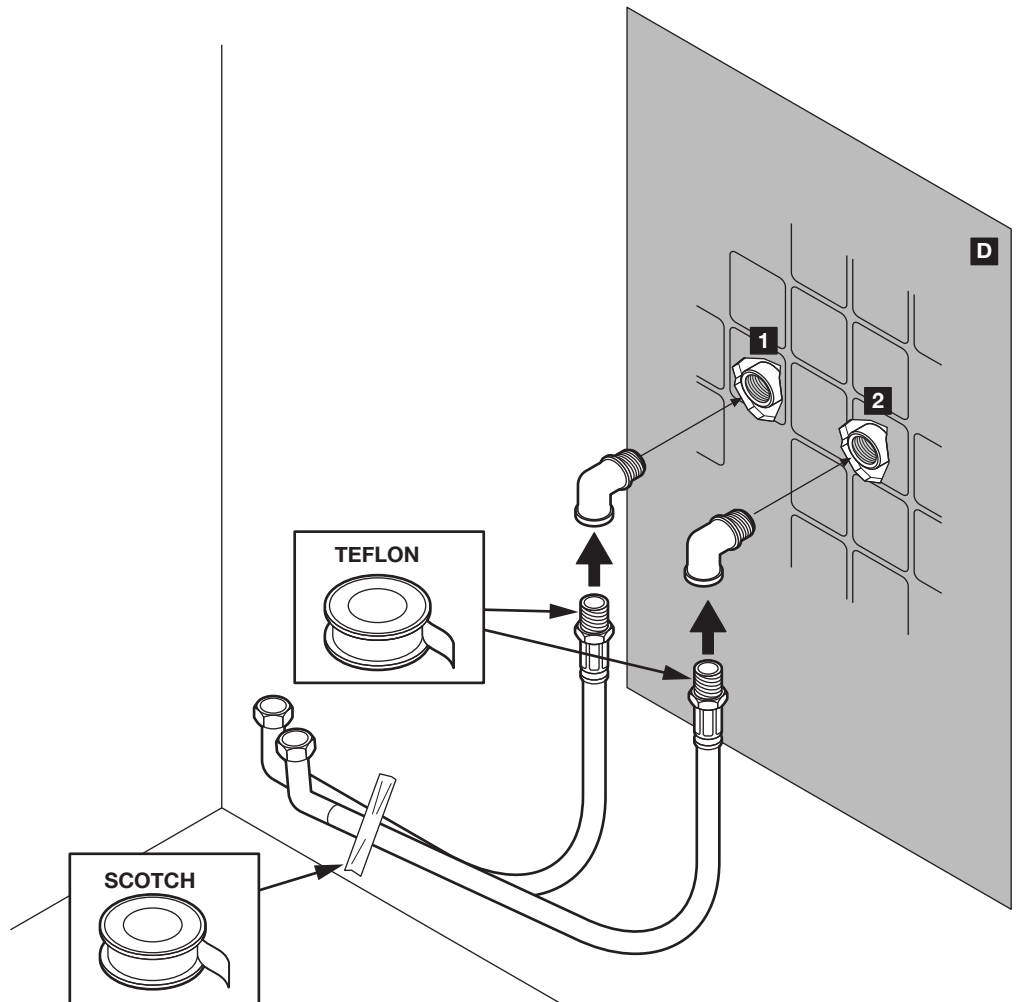
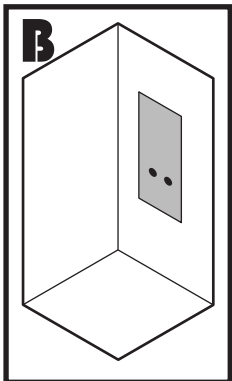

2

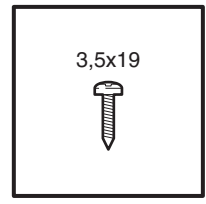
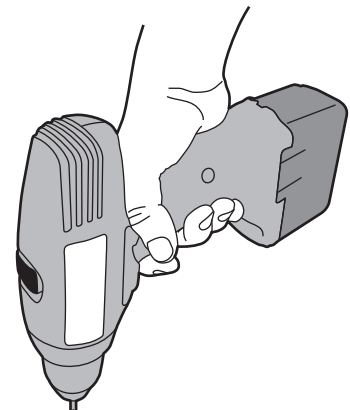
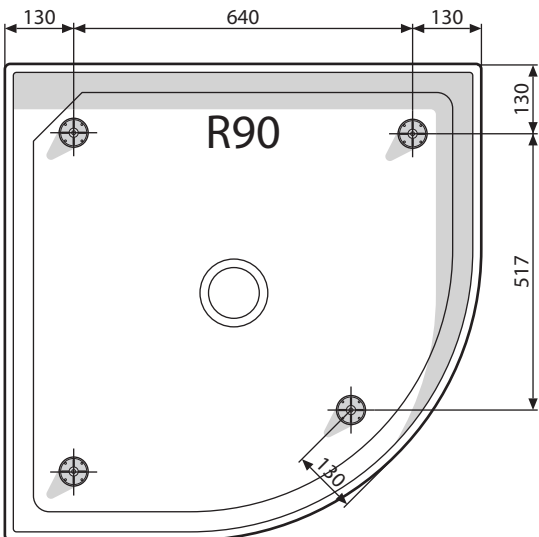
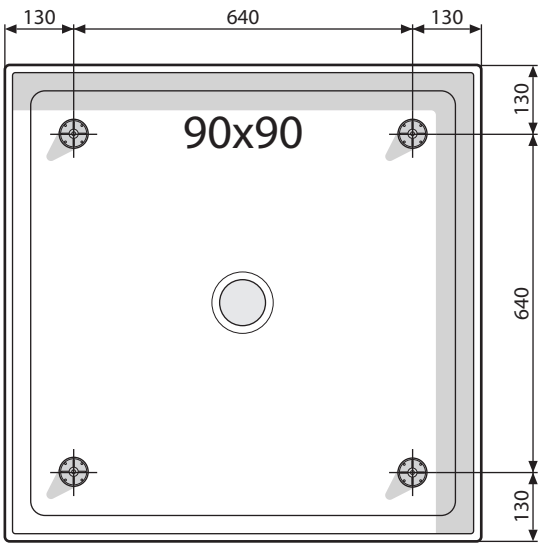
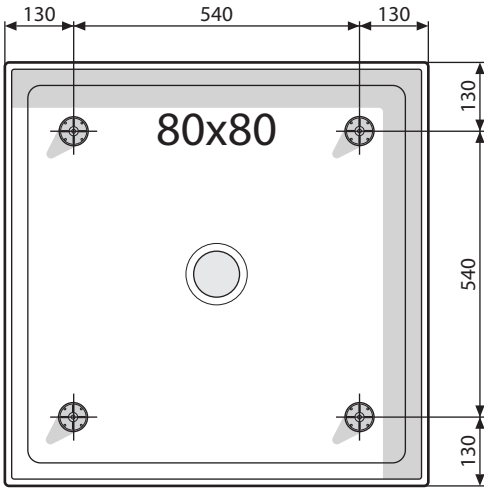
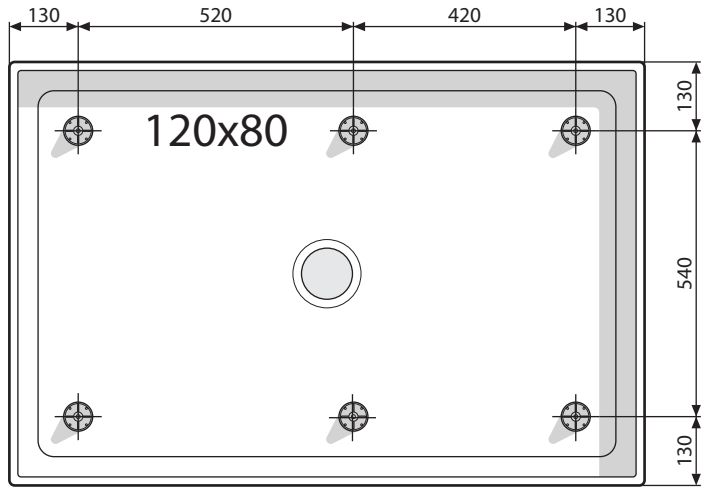
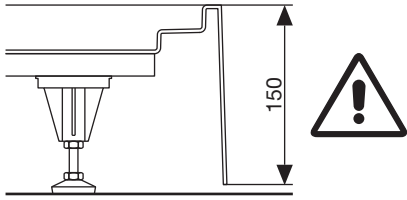

A)

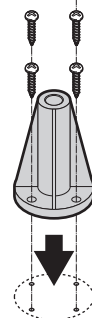

B)



C)

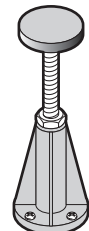

3

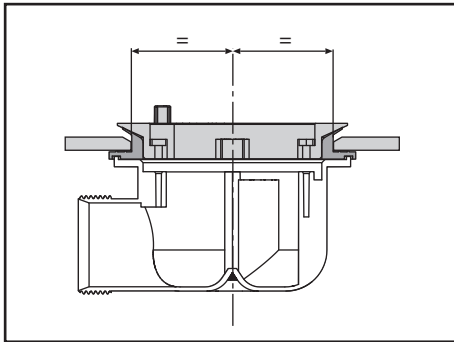
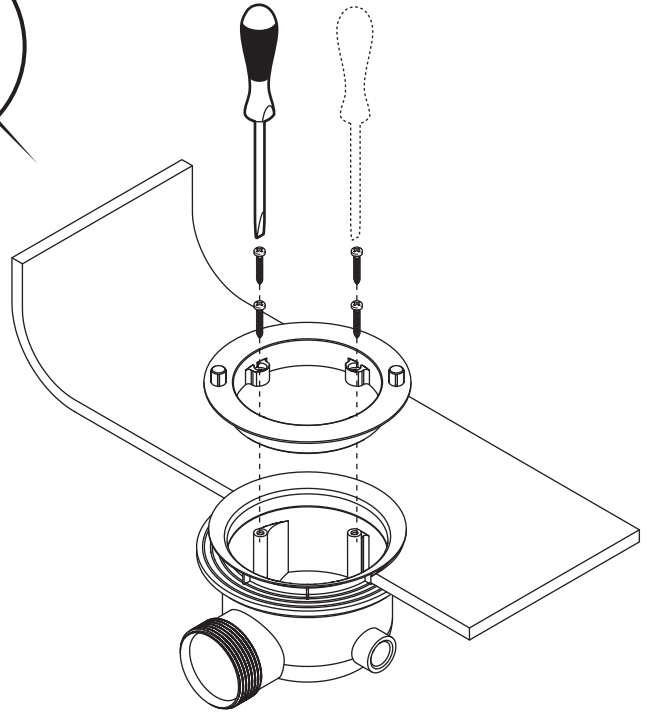
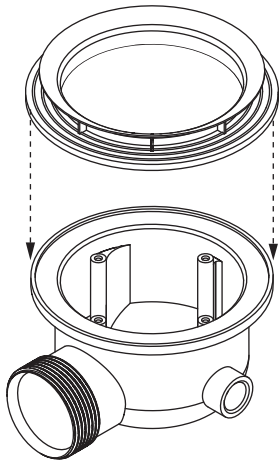

4

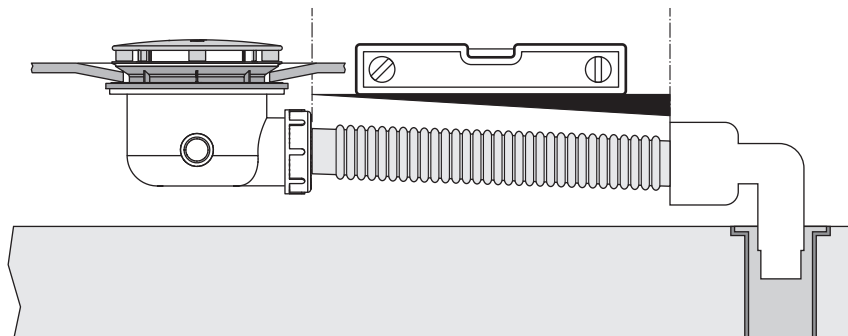
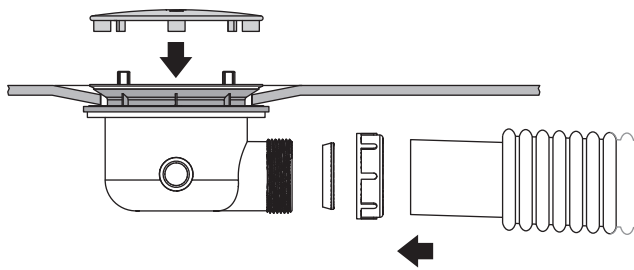

5

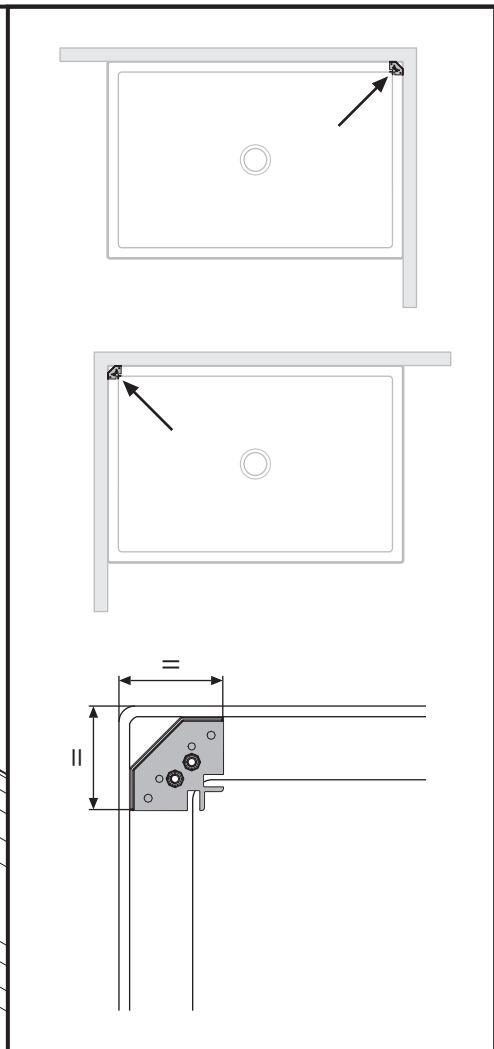
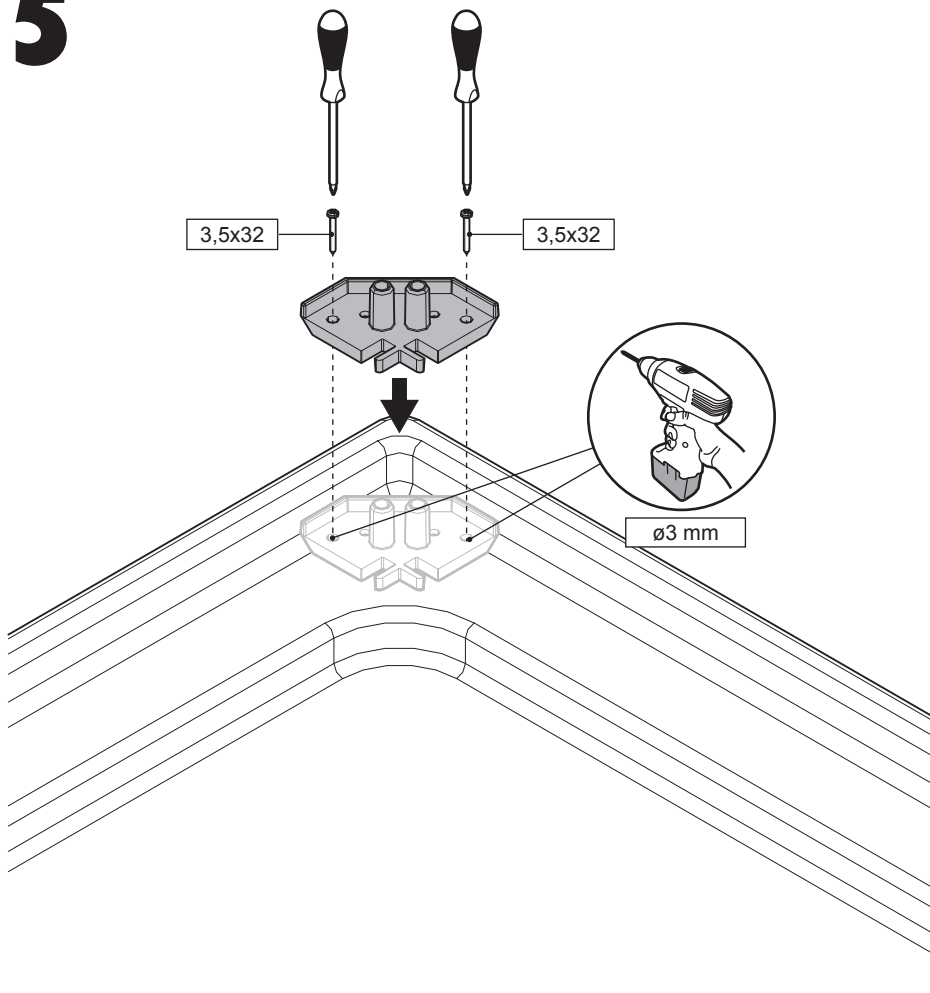

6

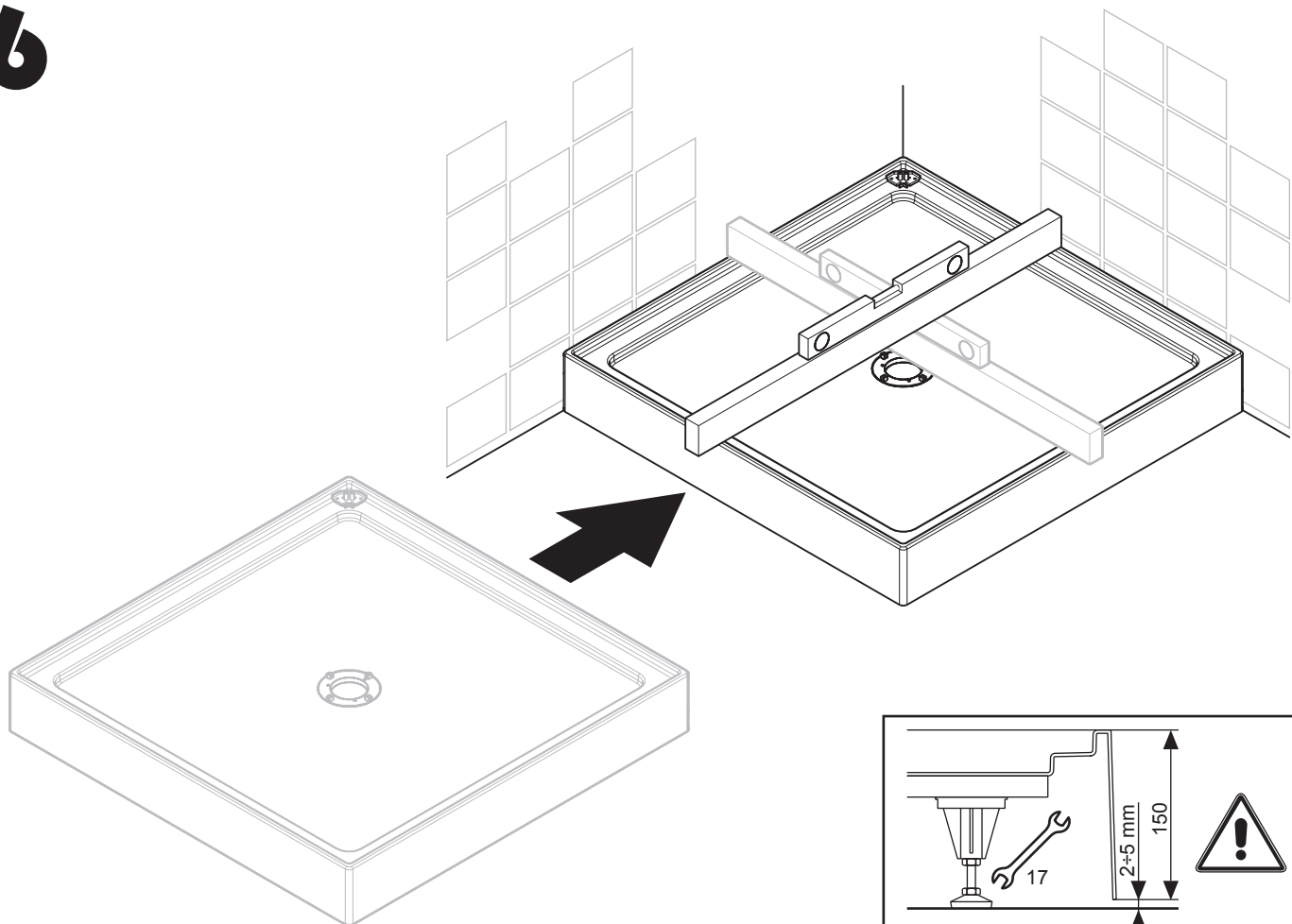

7

FR Vérification de l'étanchéité
EN Waterproof test
DE Prüfung der Dichtheit
NL Waterdichtheidstest

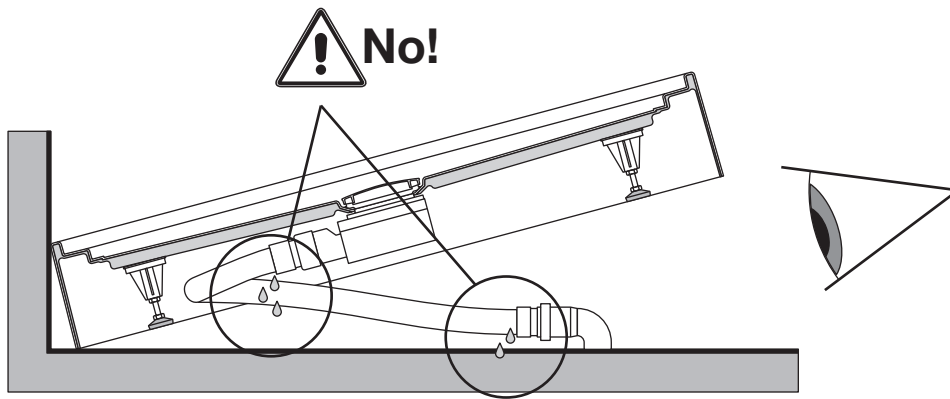
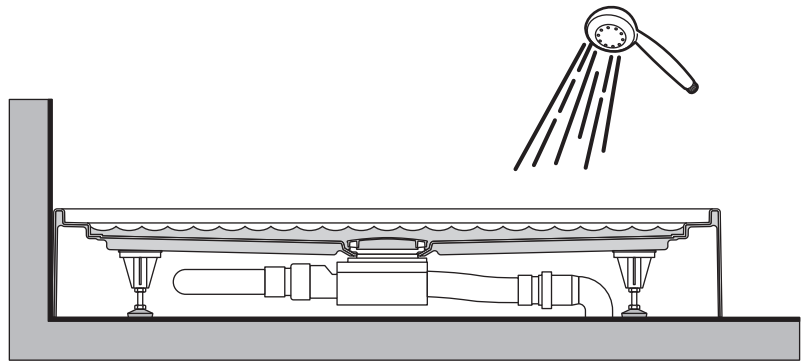

8

FR Non acétique
EN Acetic-acid free
DE Nicht essigsäurevernetzend
NL Niet zuur

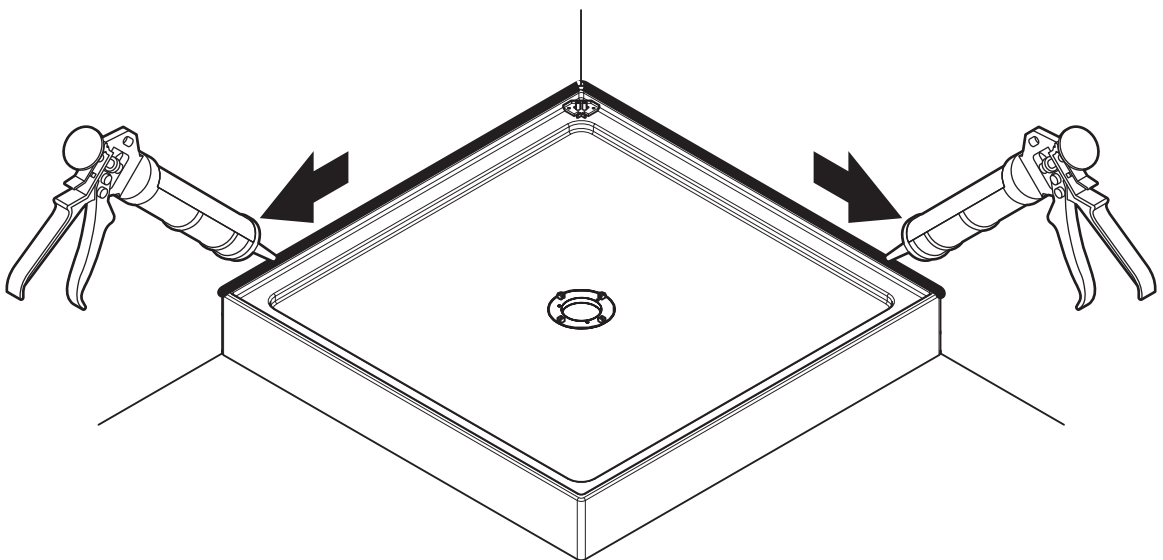

9

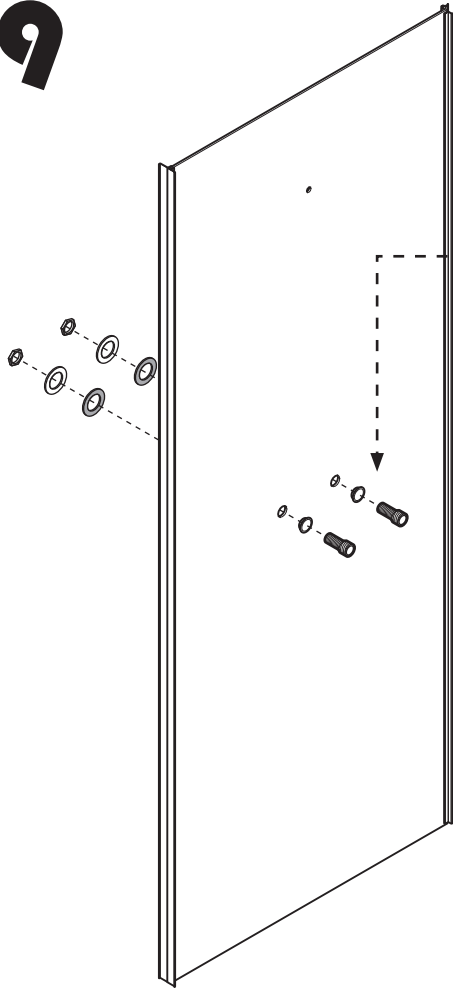

x2

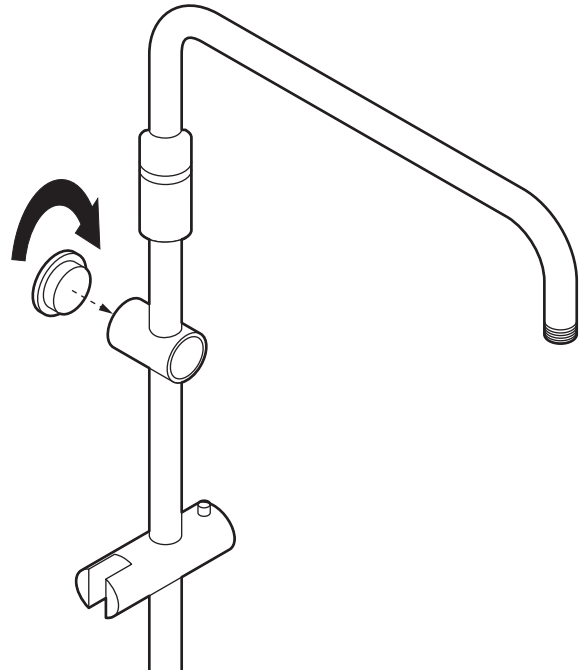
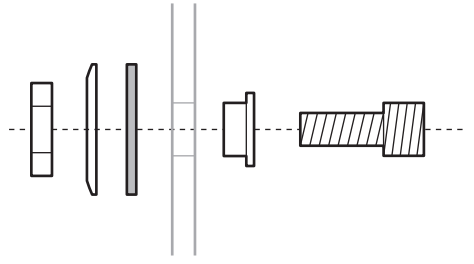

10

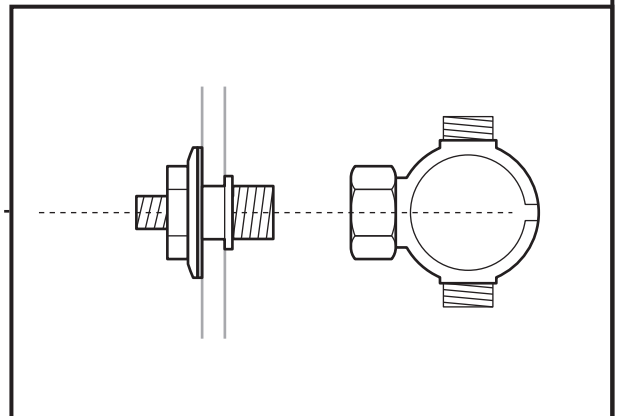
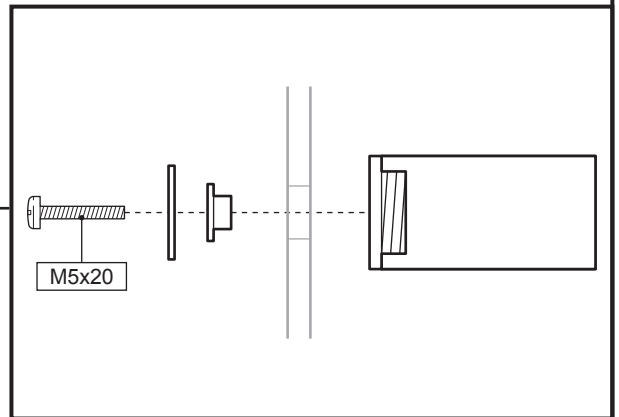
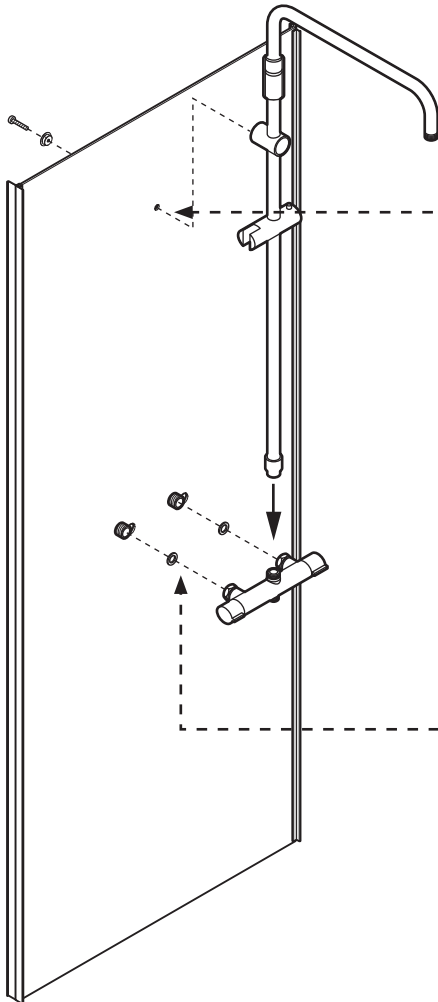

11

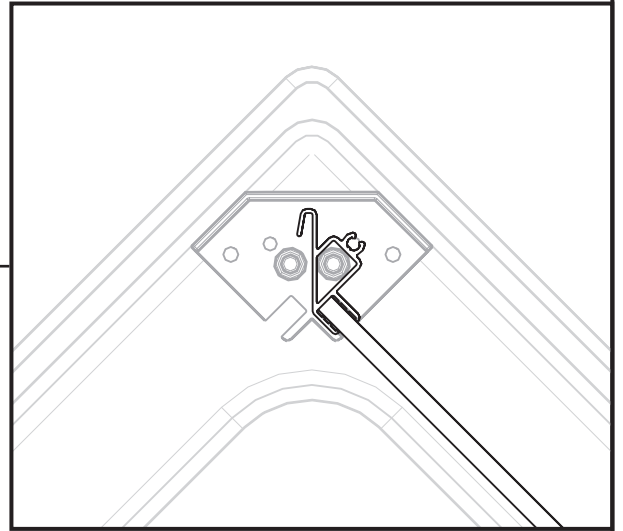
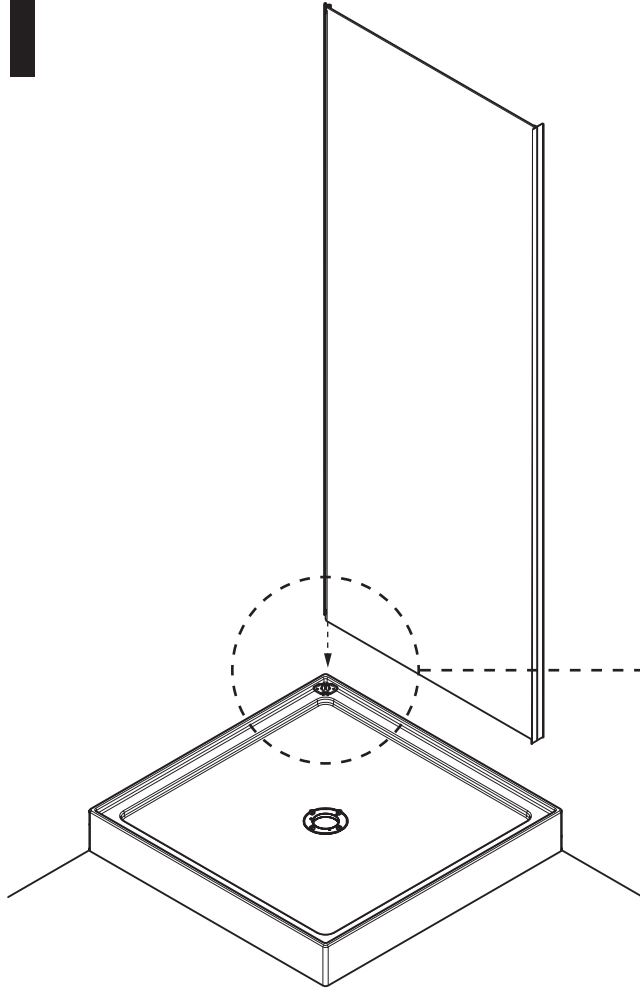

12

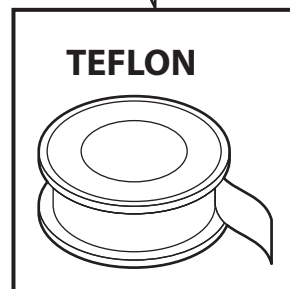
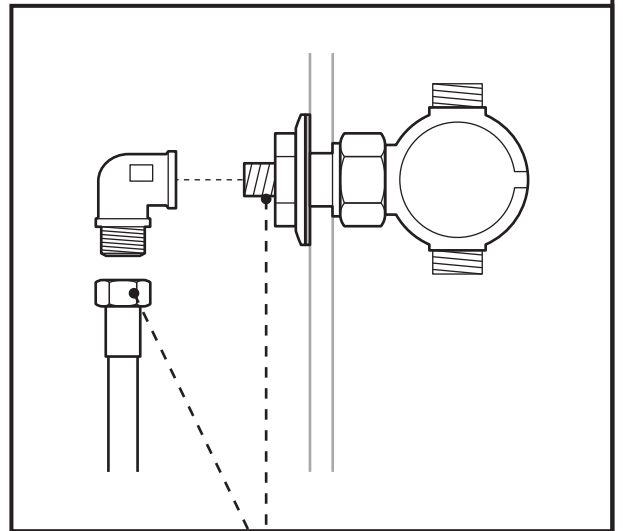
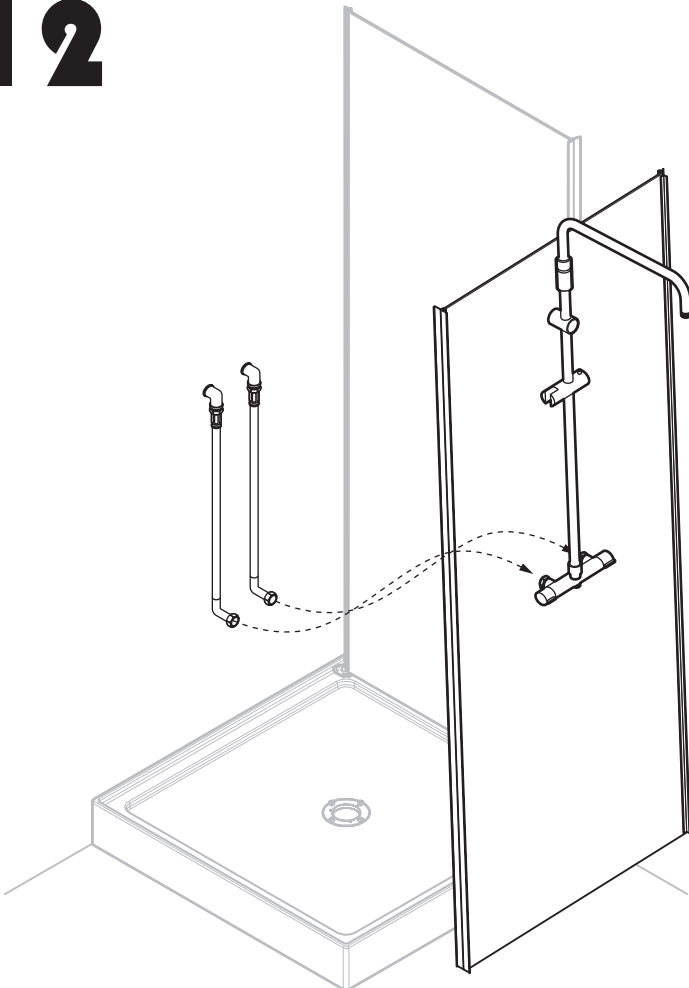

13

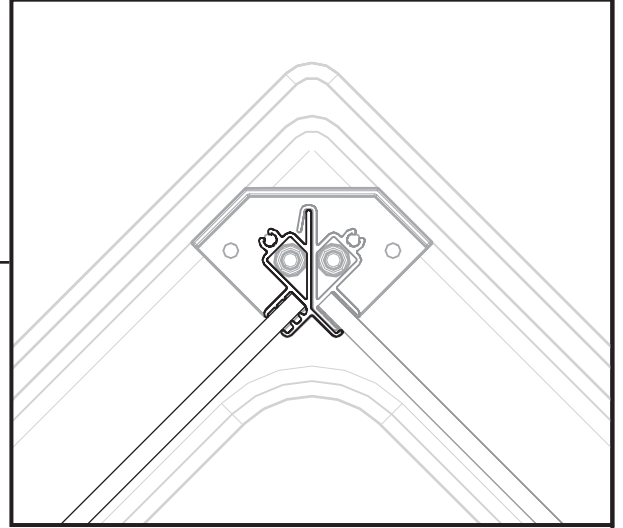
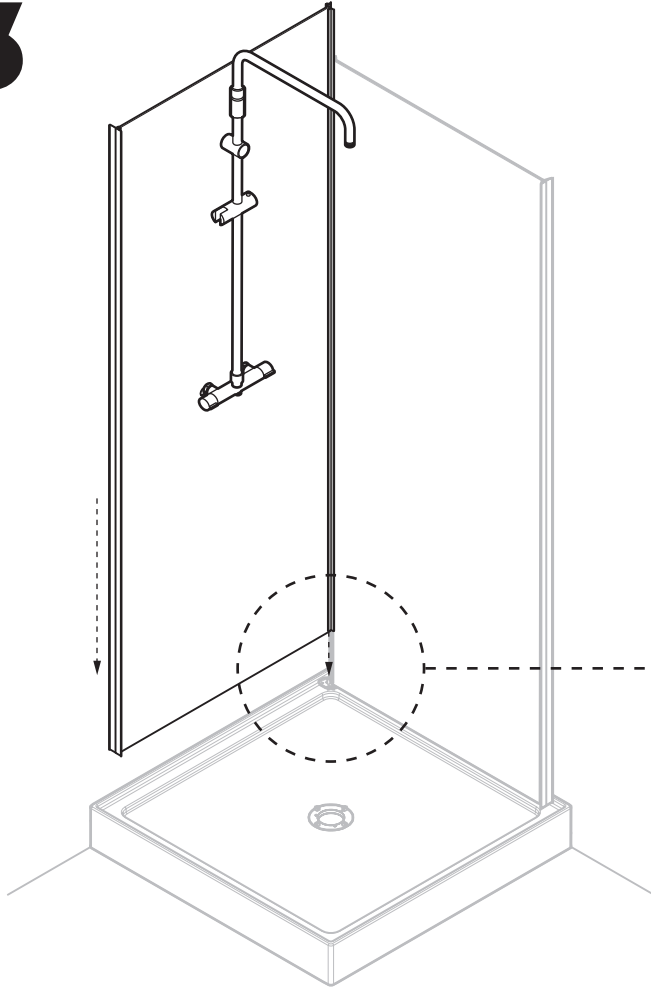

14

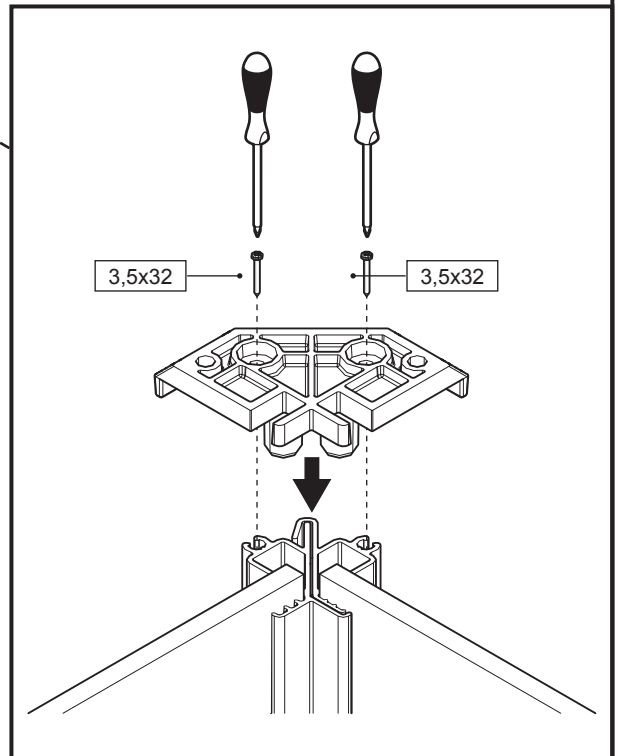
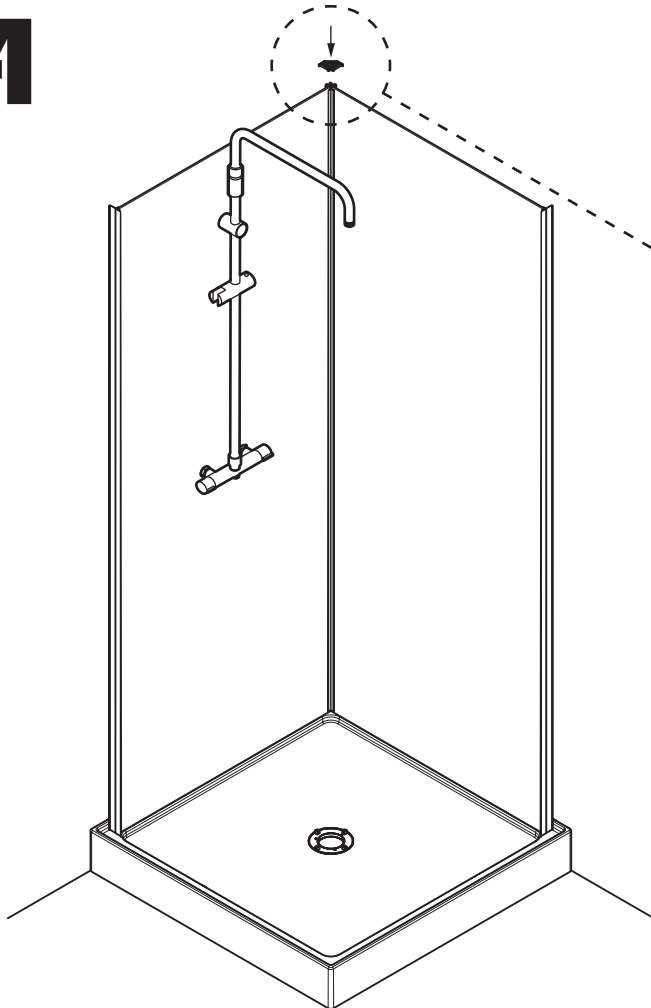

15

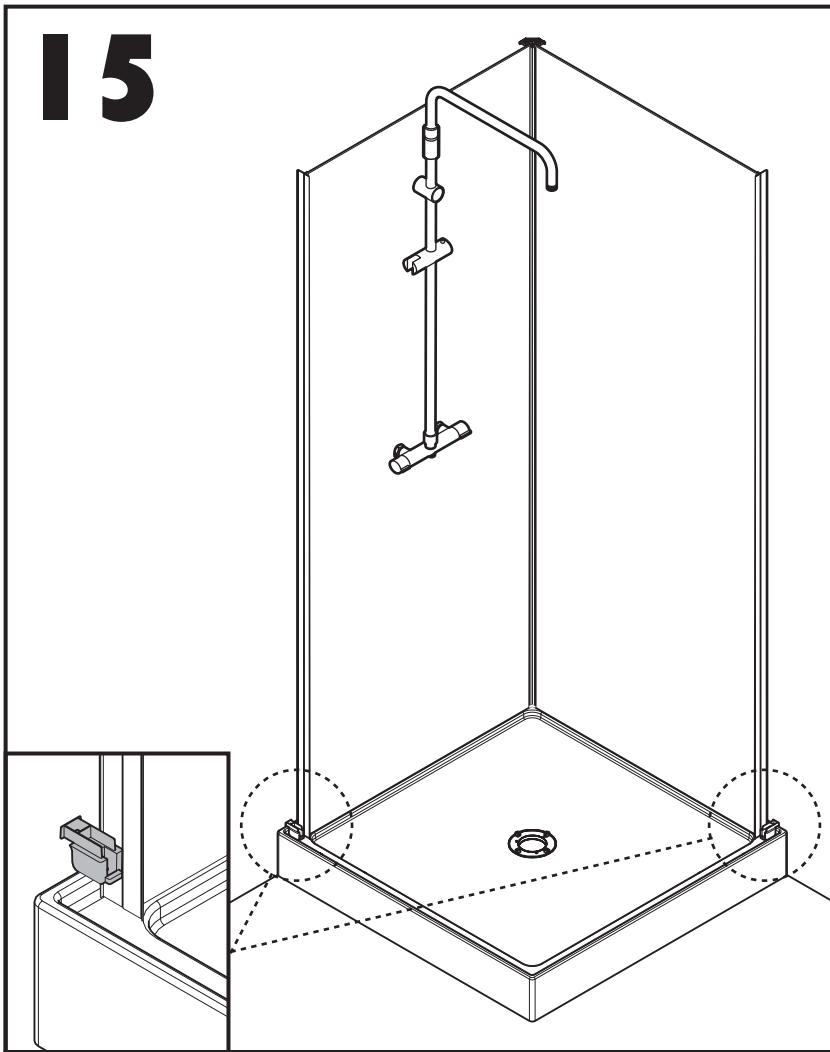

x2

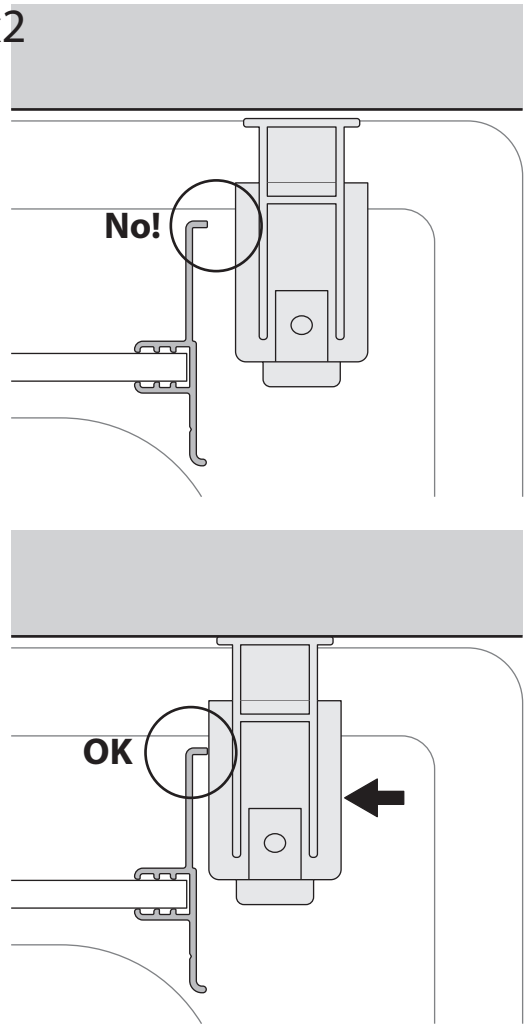

16

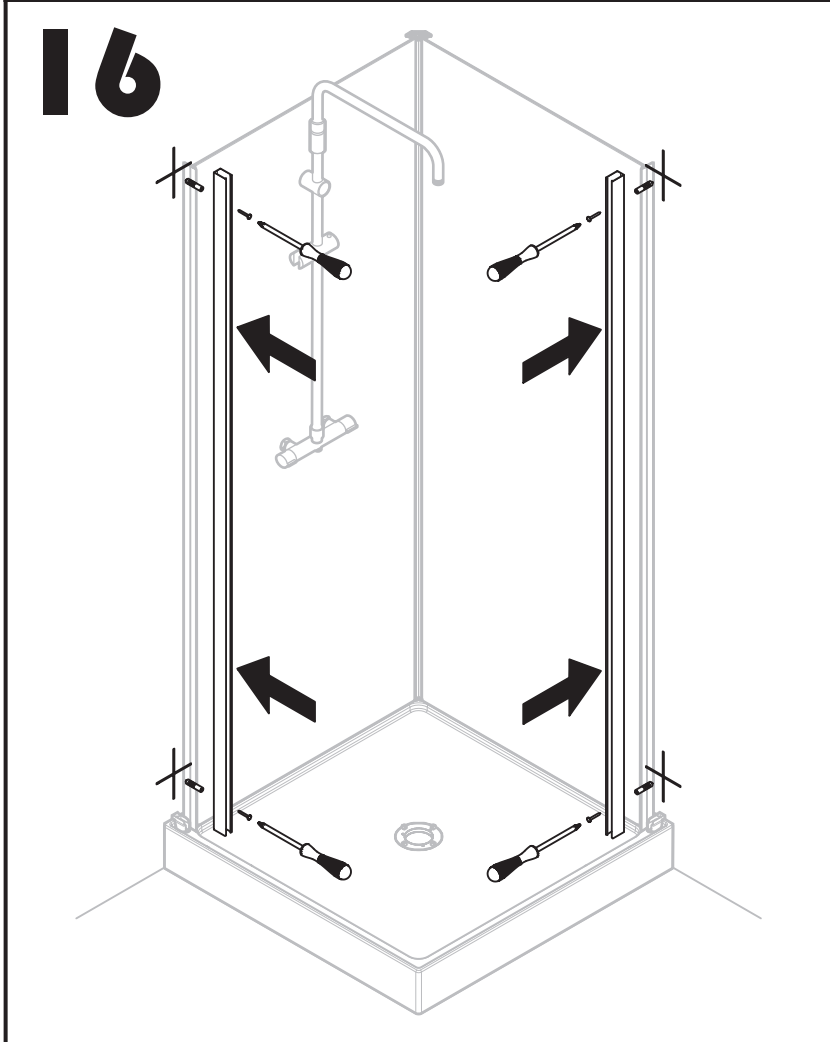

x2

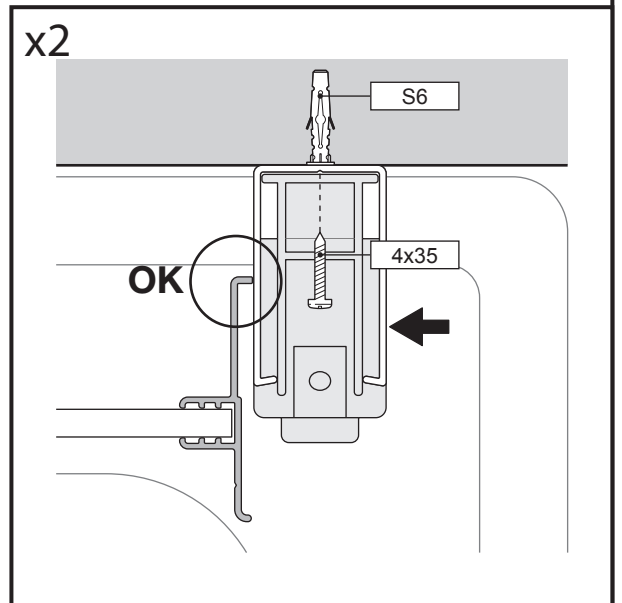

17

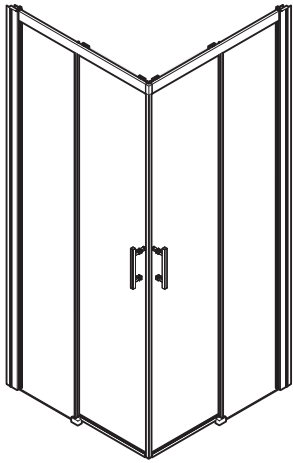
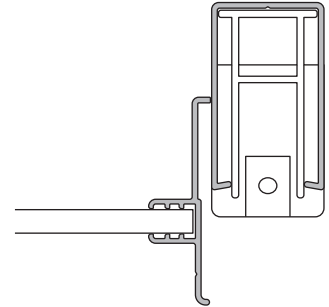
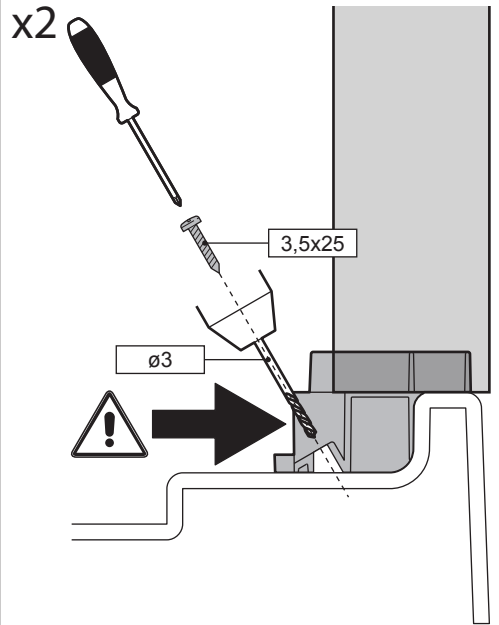
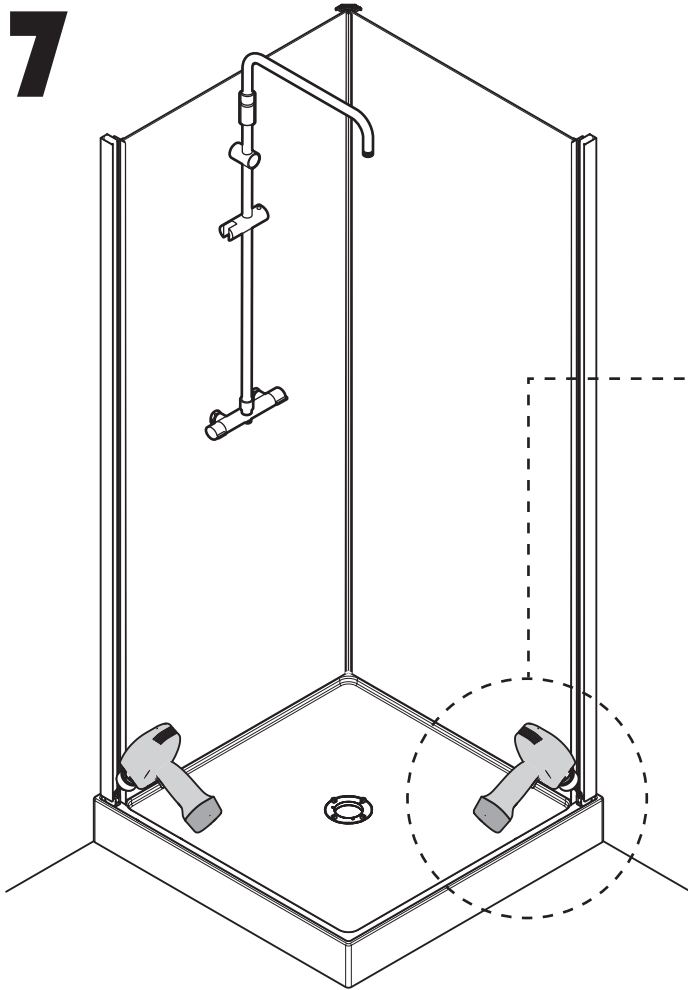

A = A90..... pag. 17

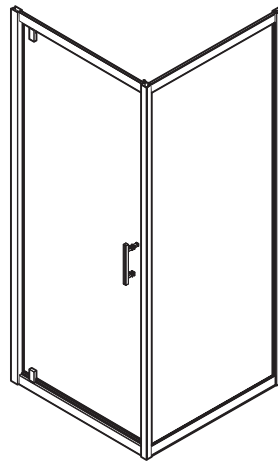

B = G90 pag. 22

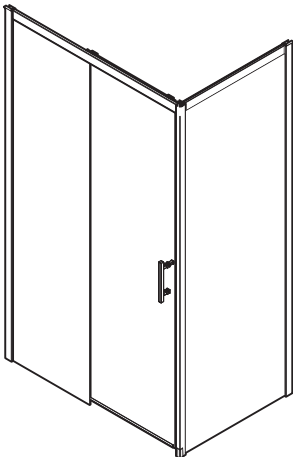

C = 2P 120..... pag. 26

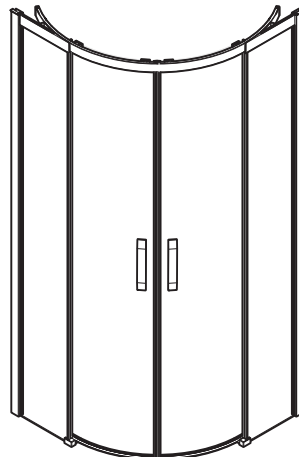

D = R90 pag. 32

A

A 90

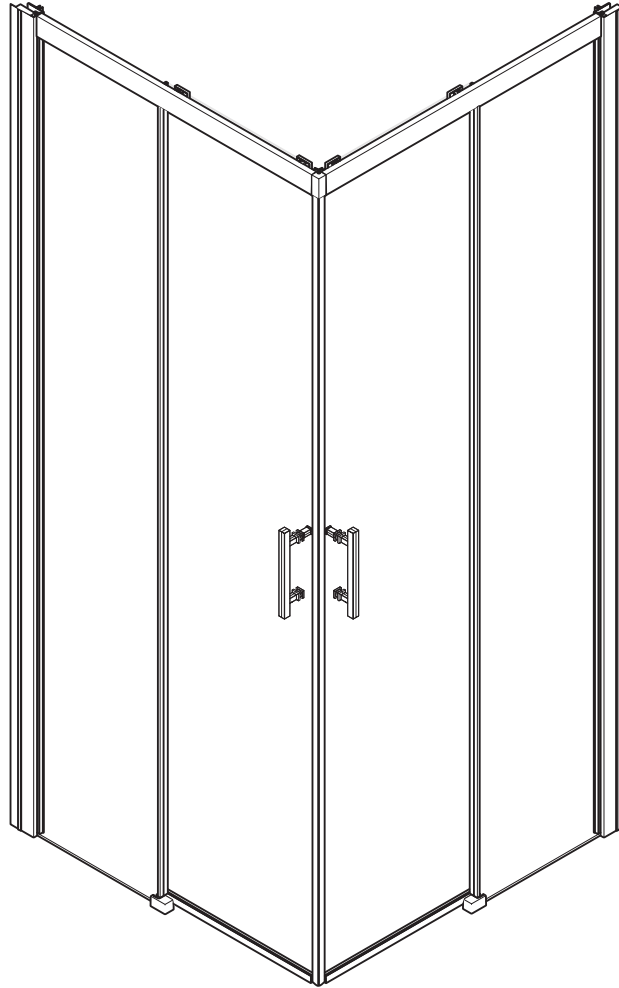

A I

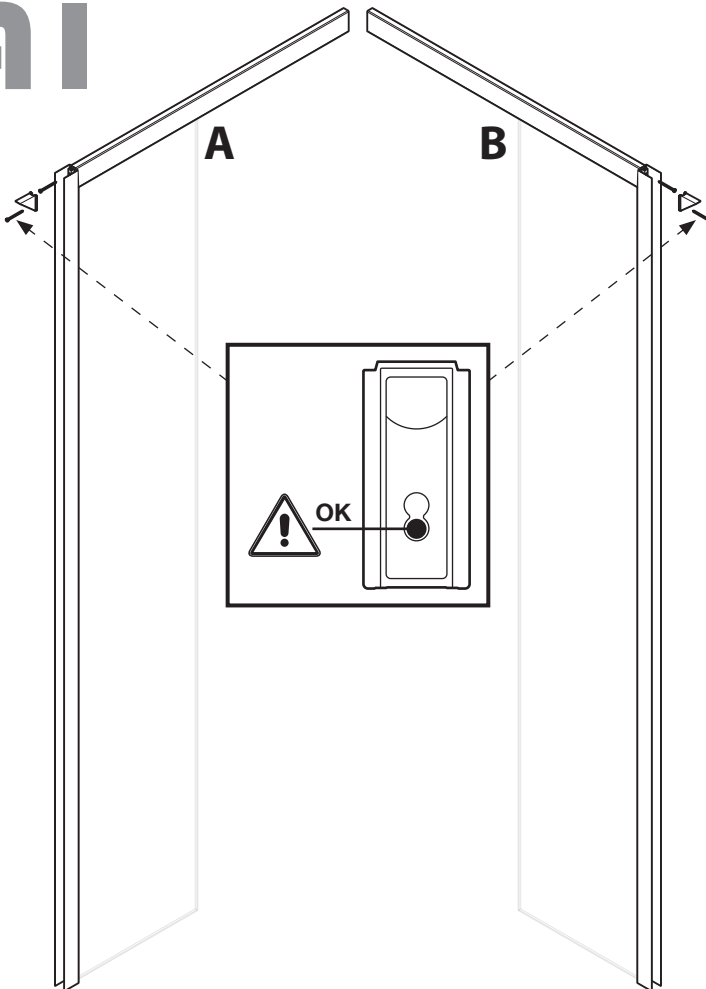

x2

3,5x45 n°4

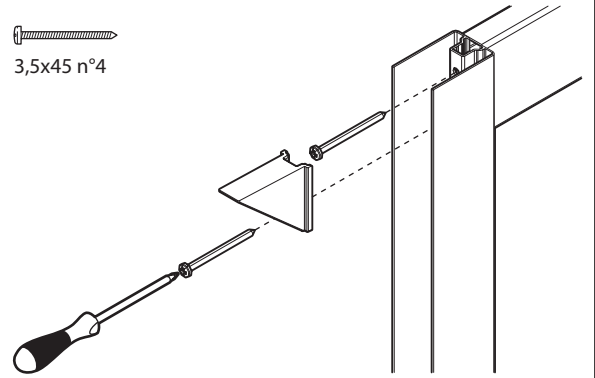

A-B

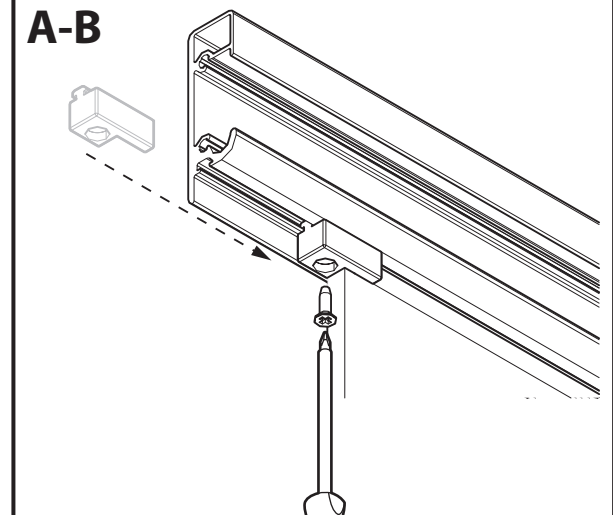

A2

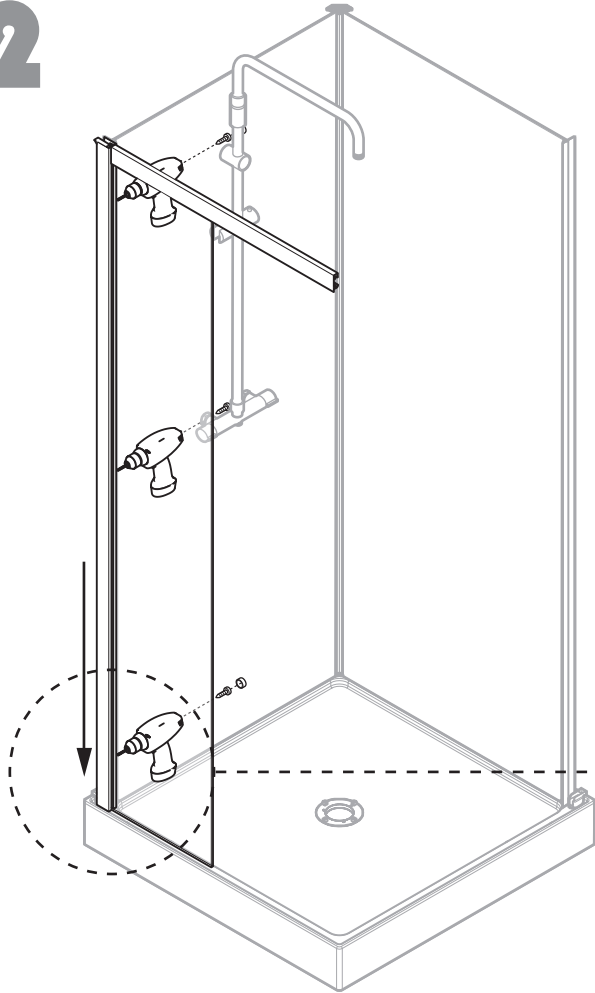

x3

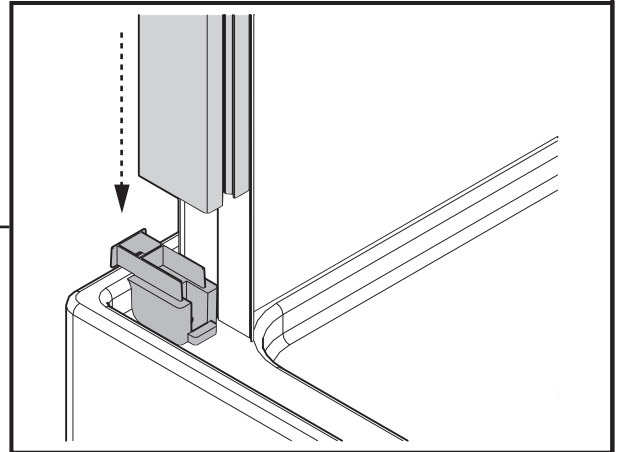
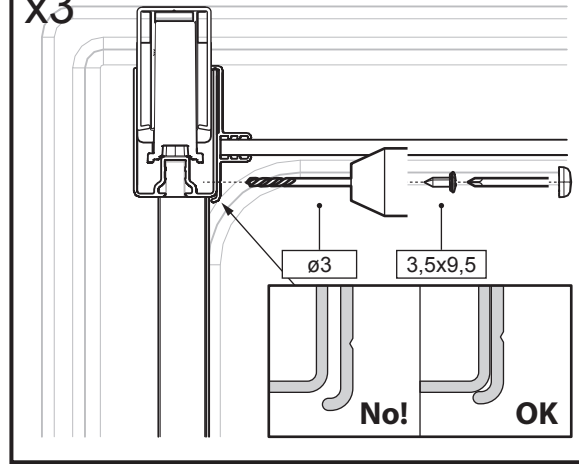

A3

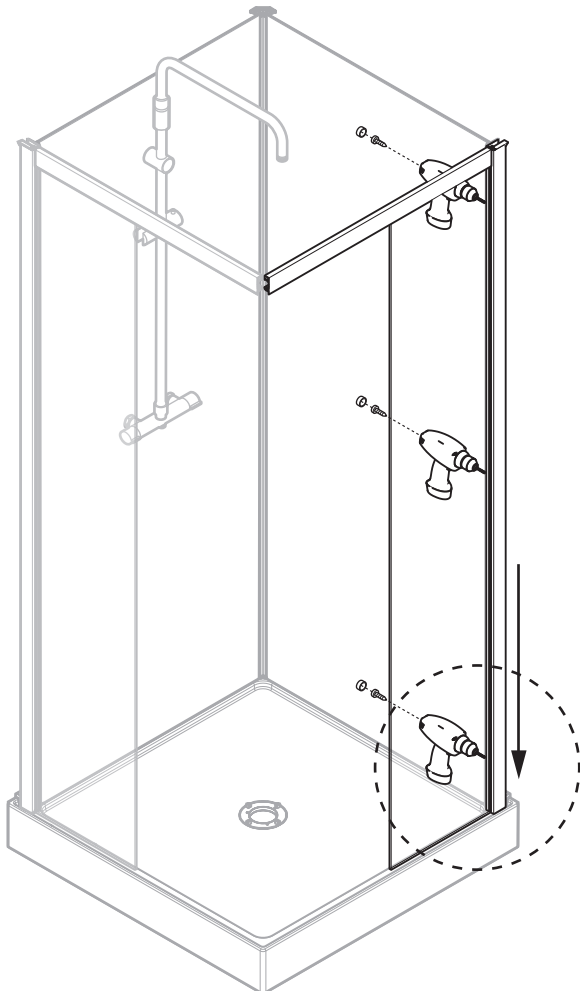

x3

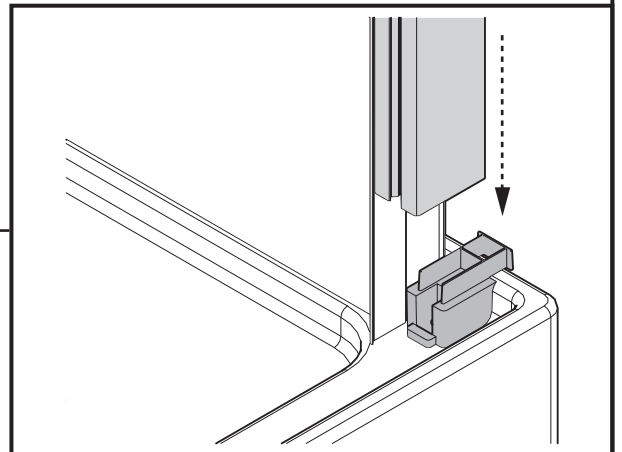
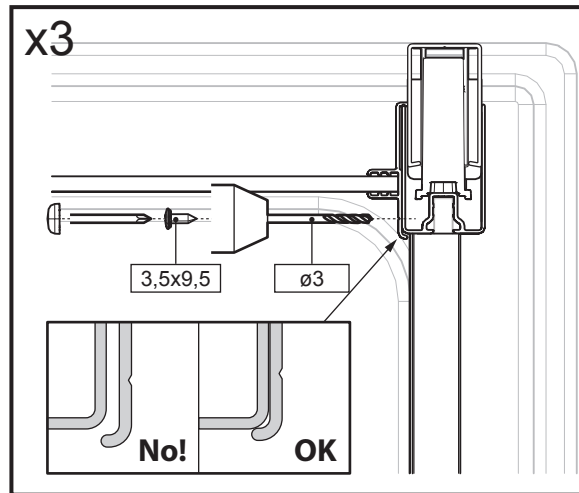

A4

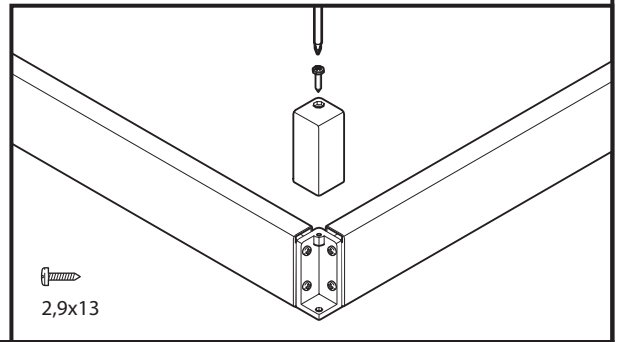
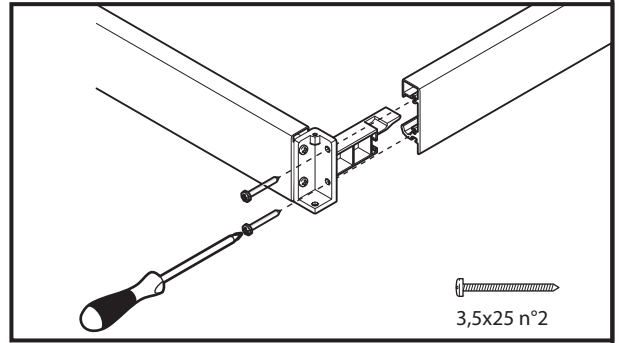
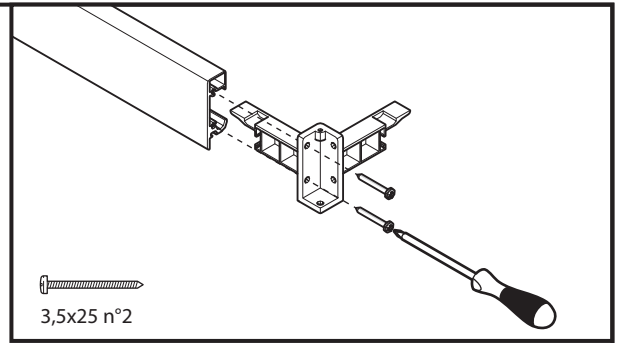
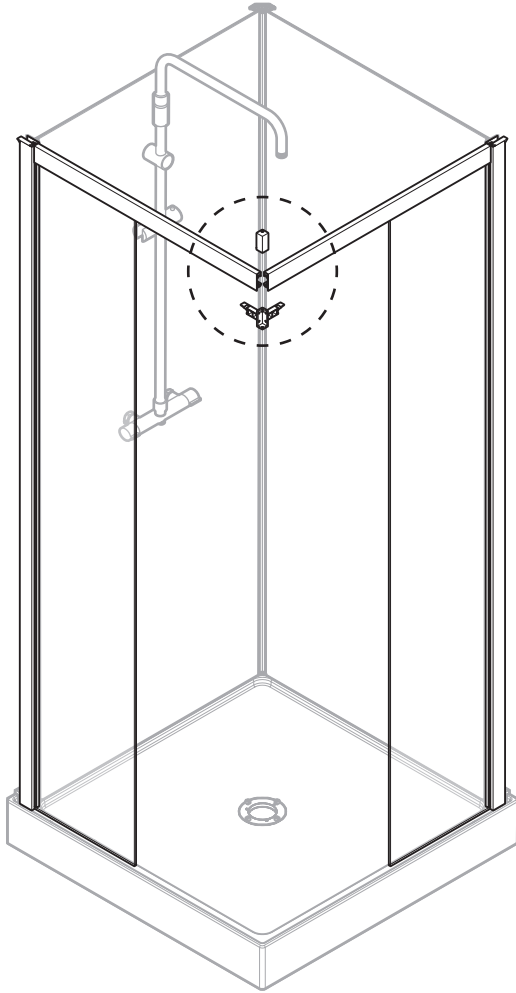

A5

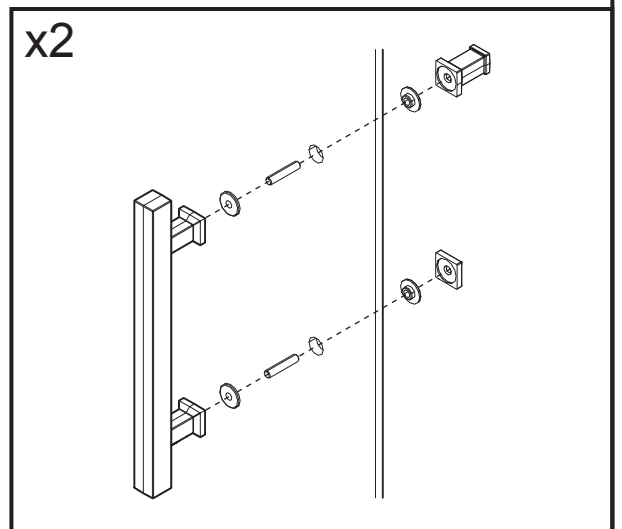
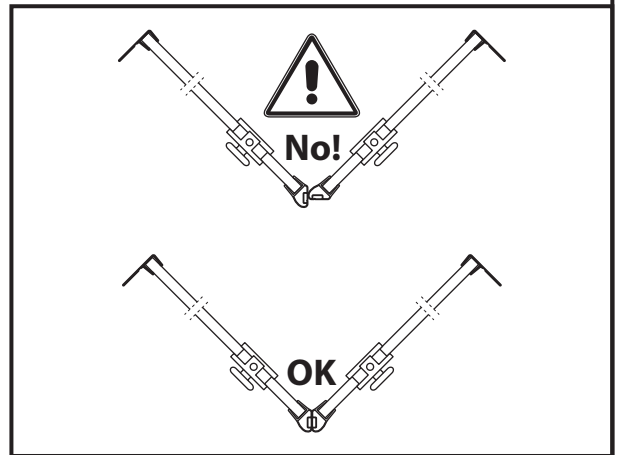
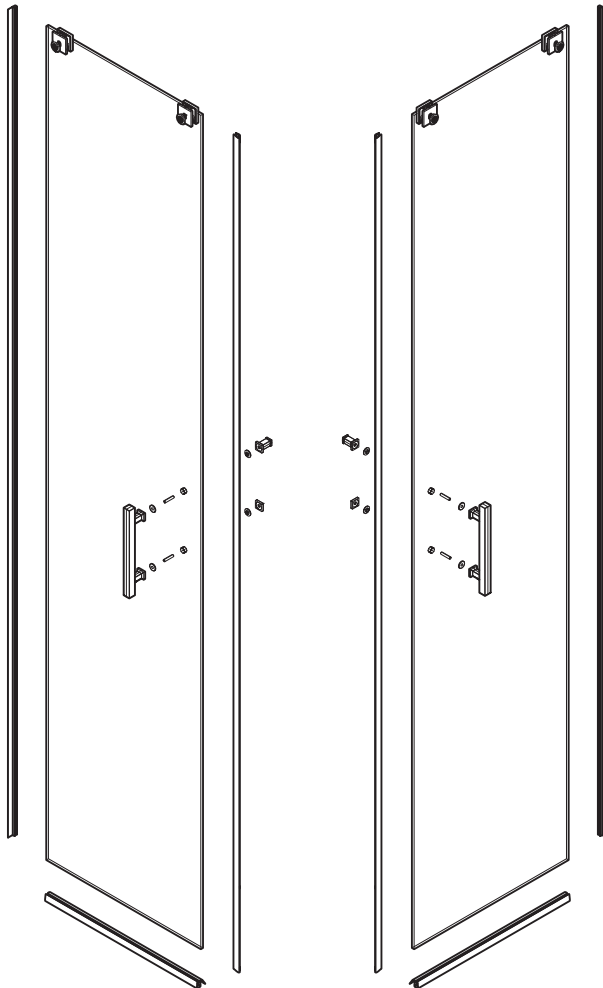

A6



x2

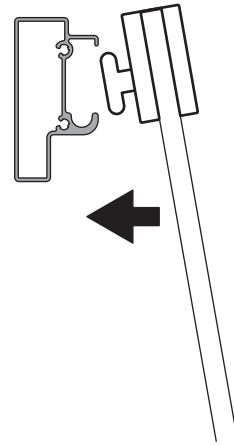

A7

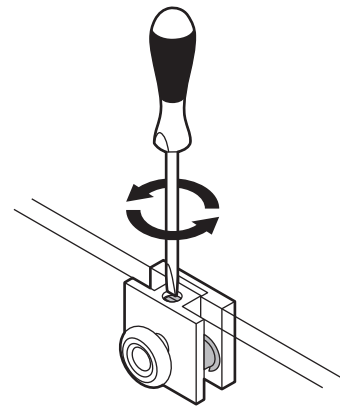
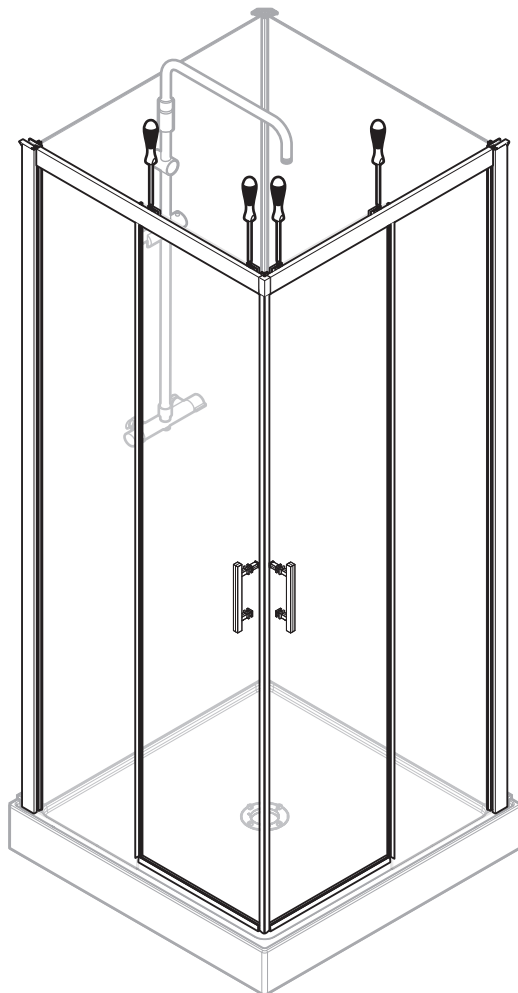

No!

OK

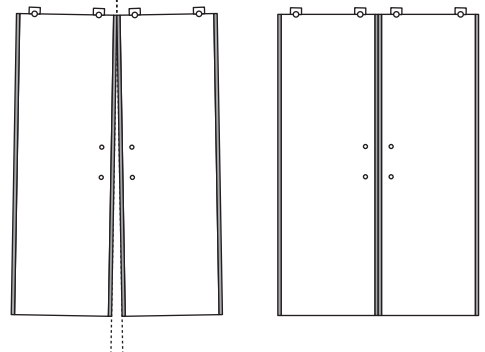

A8

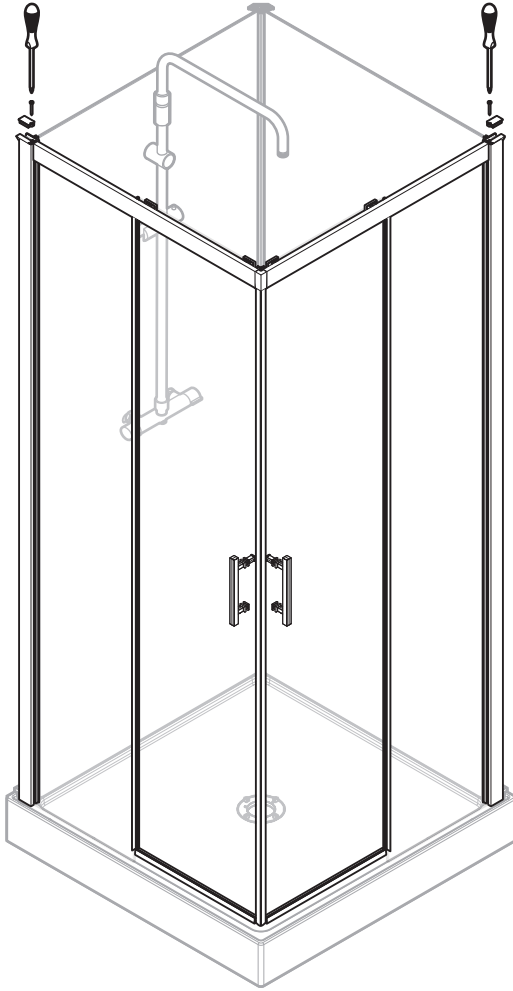

x2

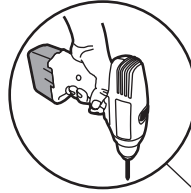

ø3 mm



3,5x13

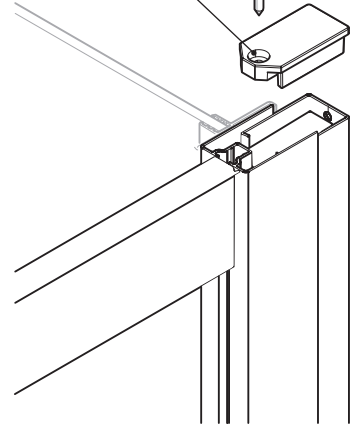

B

G 90

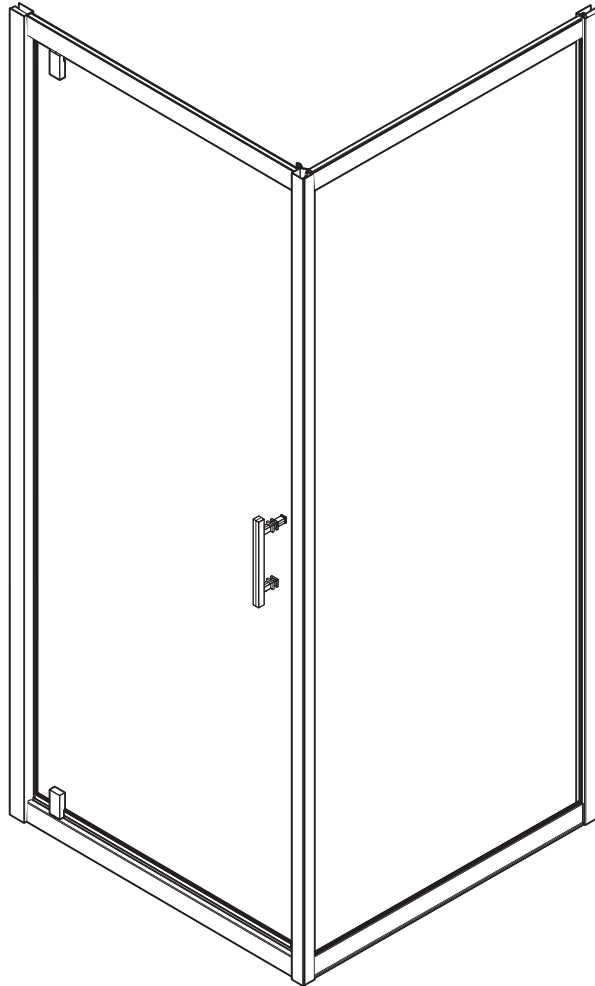

BI

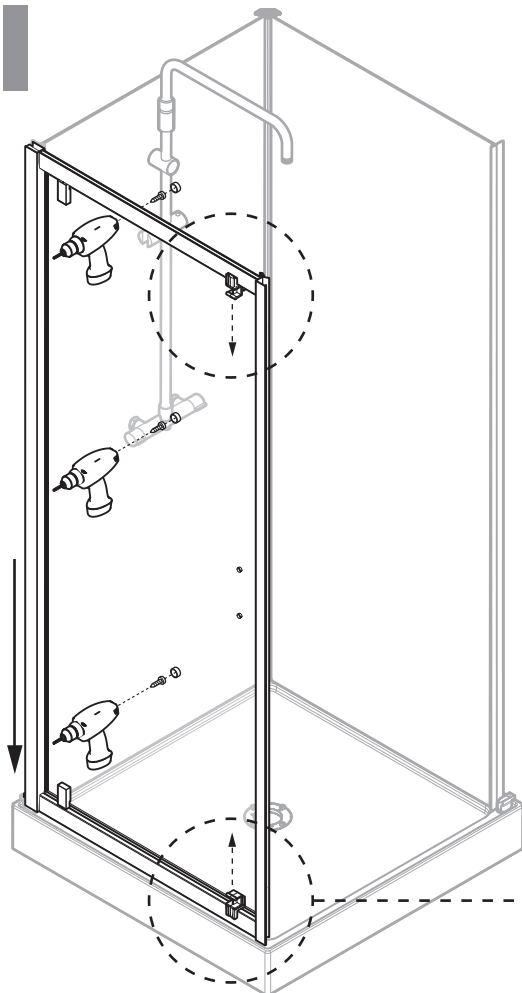

x3

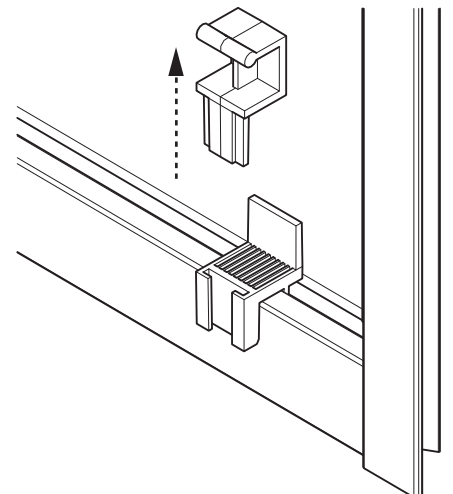
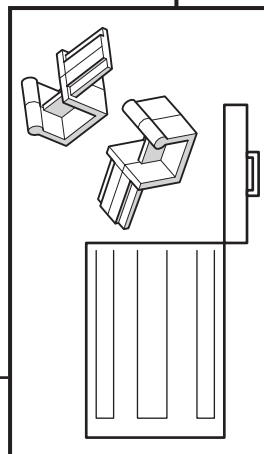
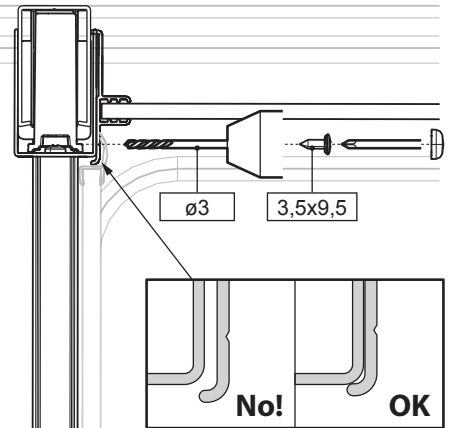

B2

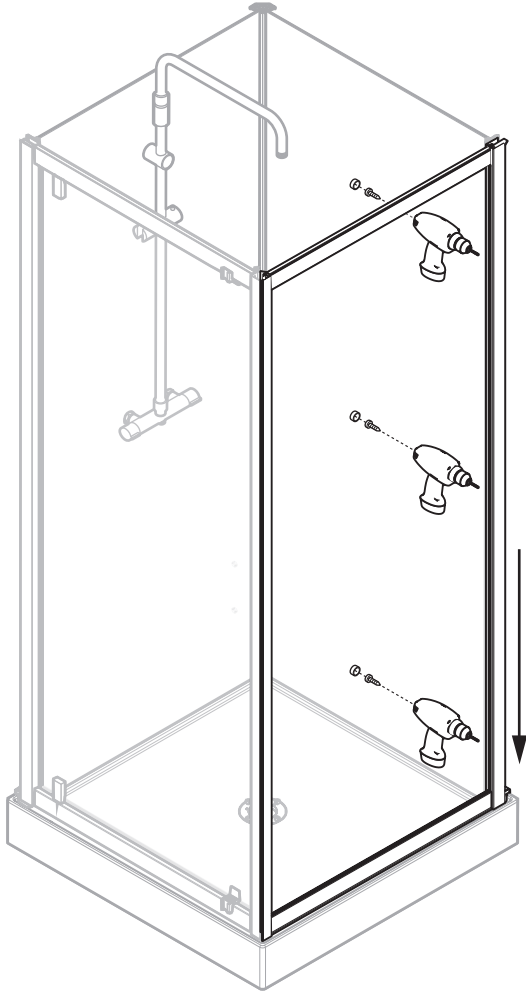

x3

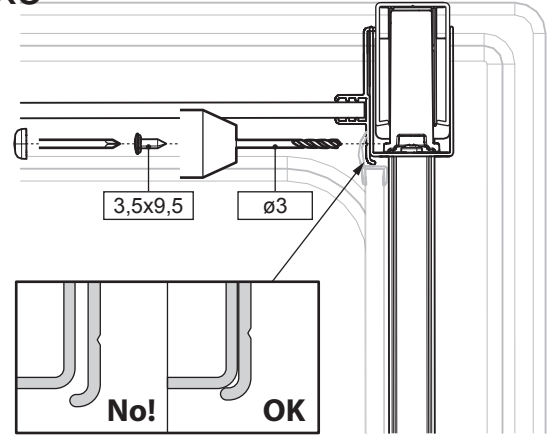

B3

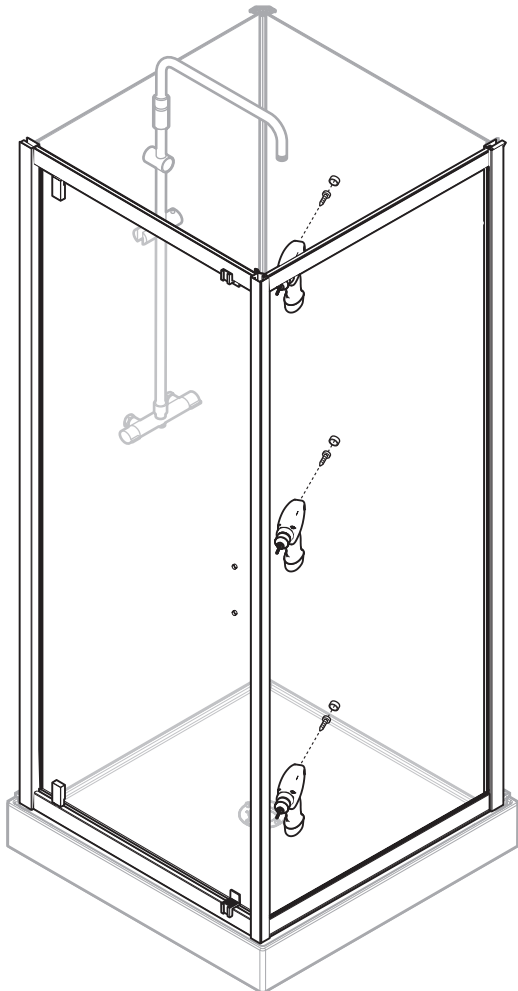

x3

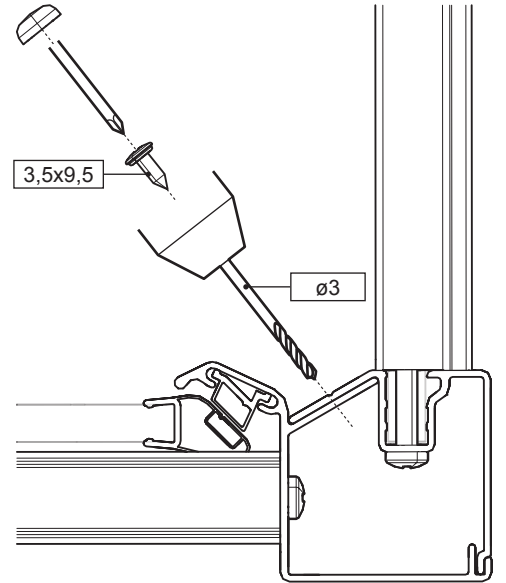

B4

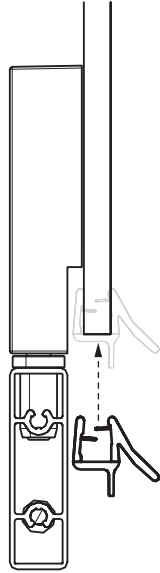
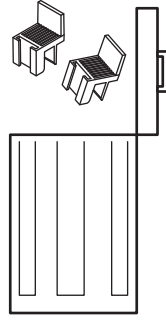
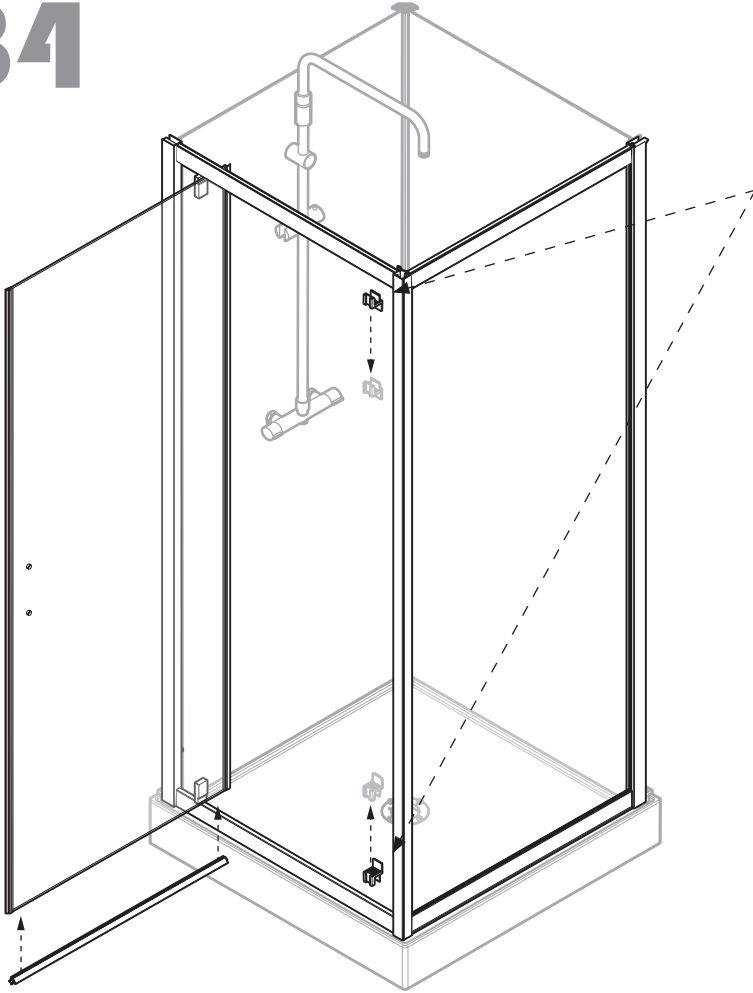

B5

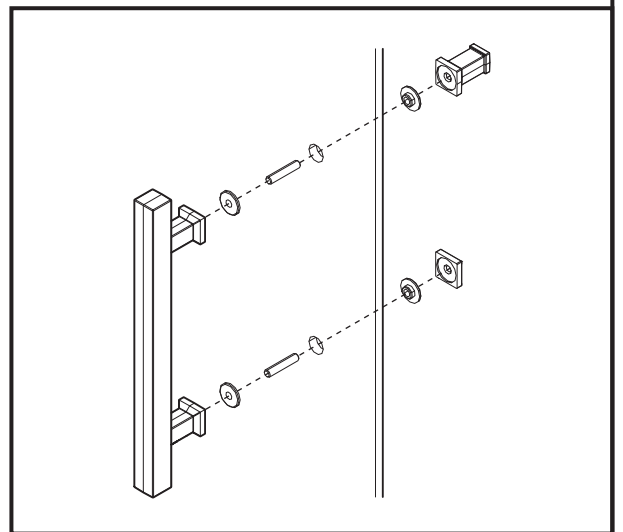
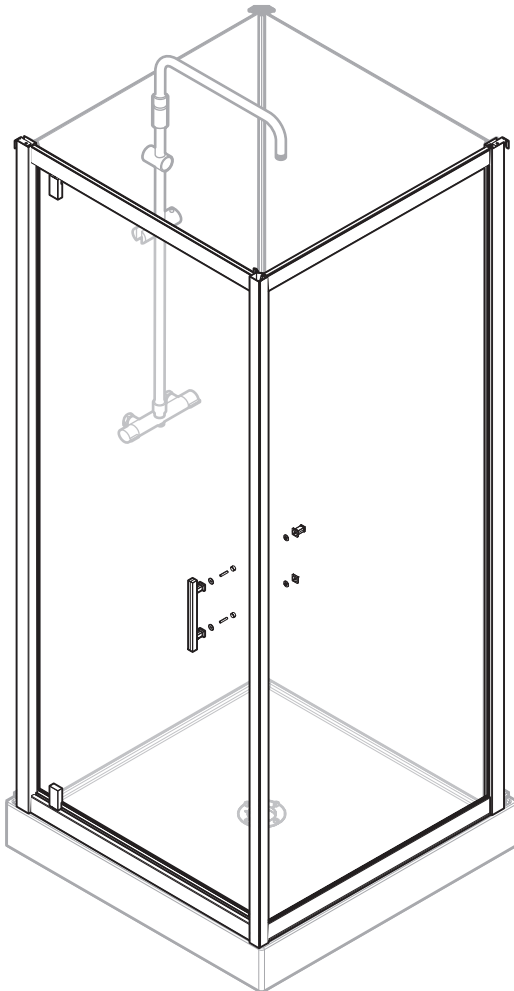

B6

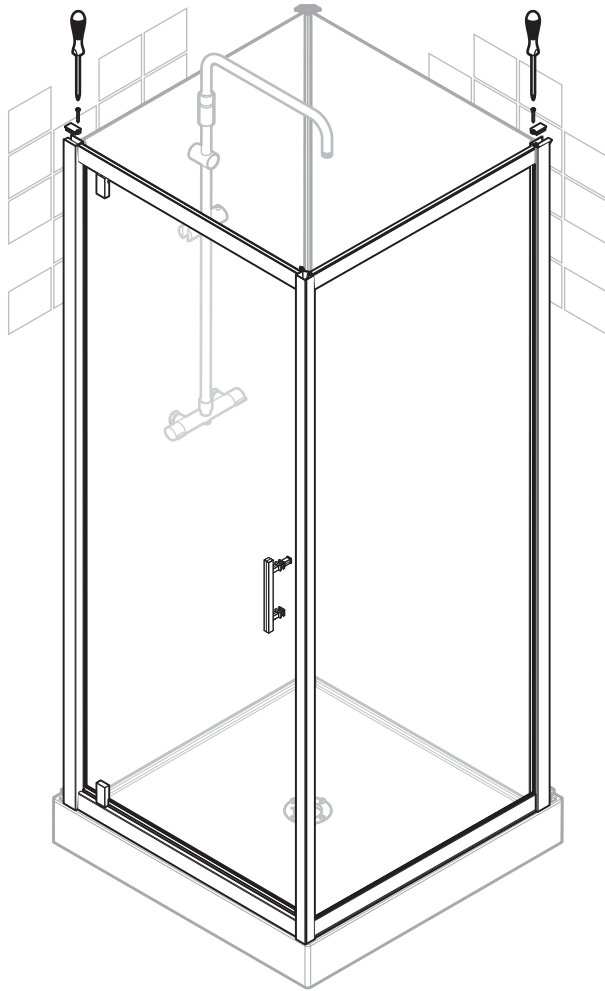

x2

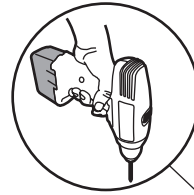

ø3 mm



3,5x13

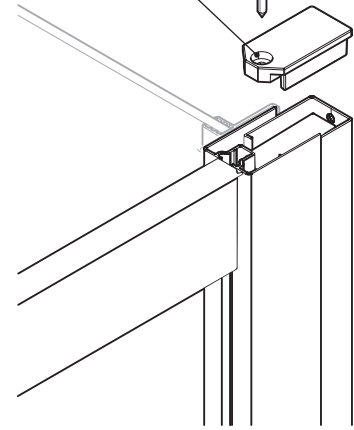

C

2P 120x80

2P 120x90

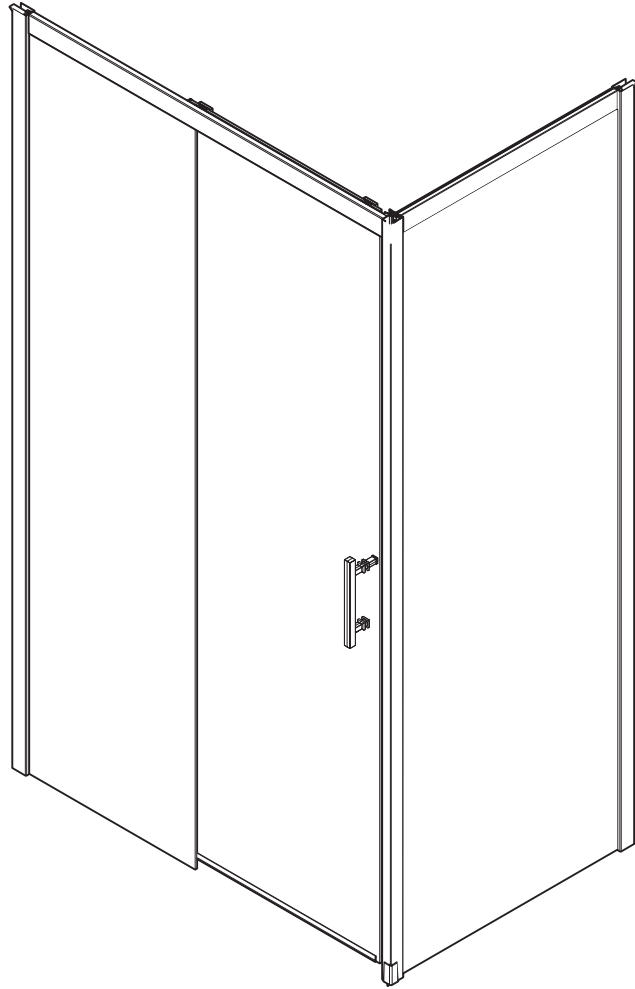

CI

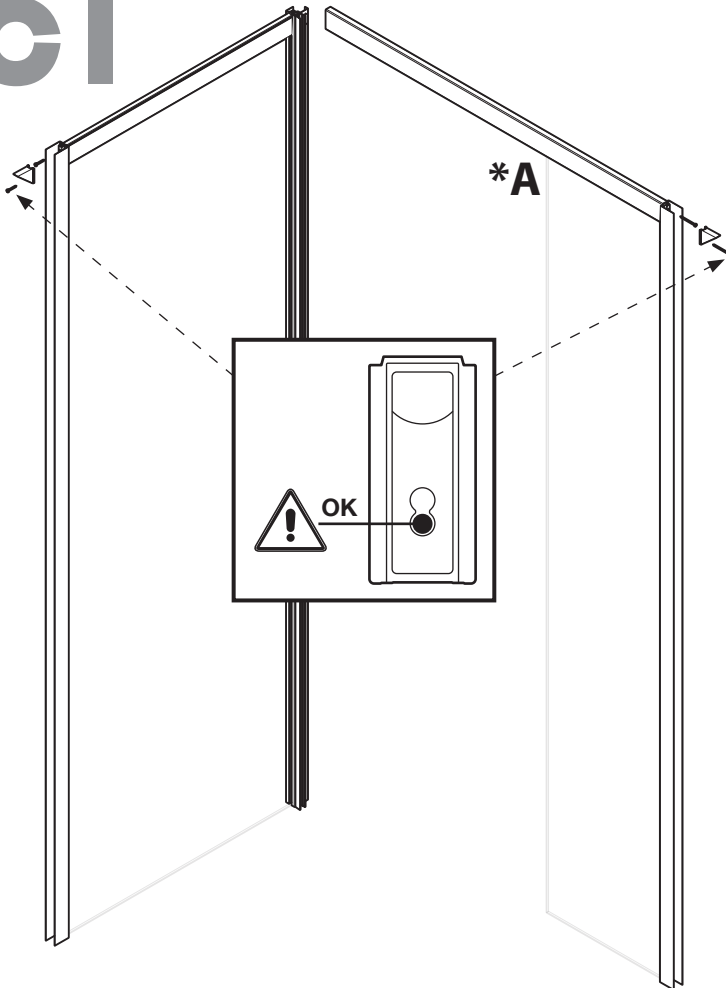

x2

3,5x45 n°4

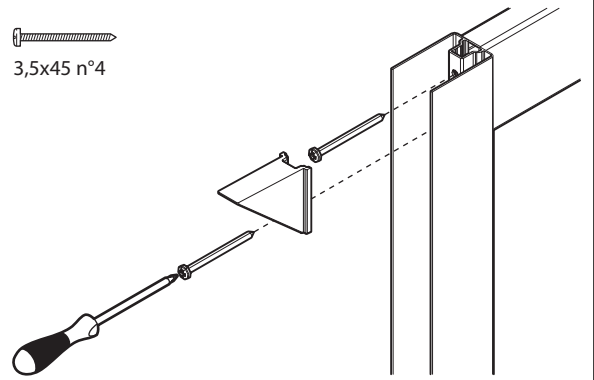

*A

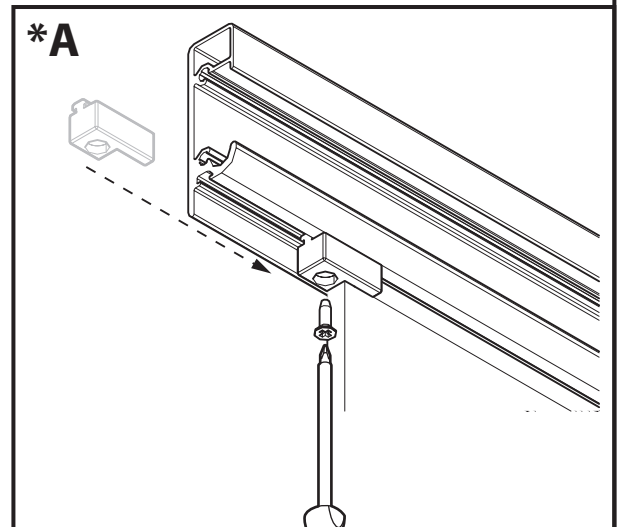

C2

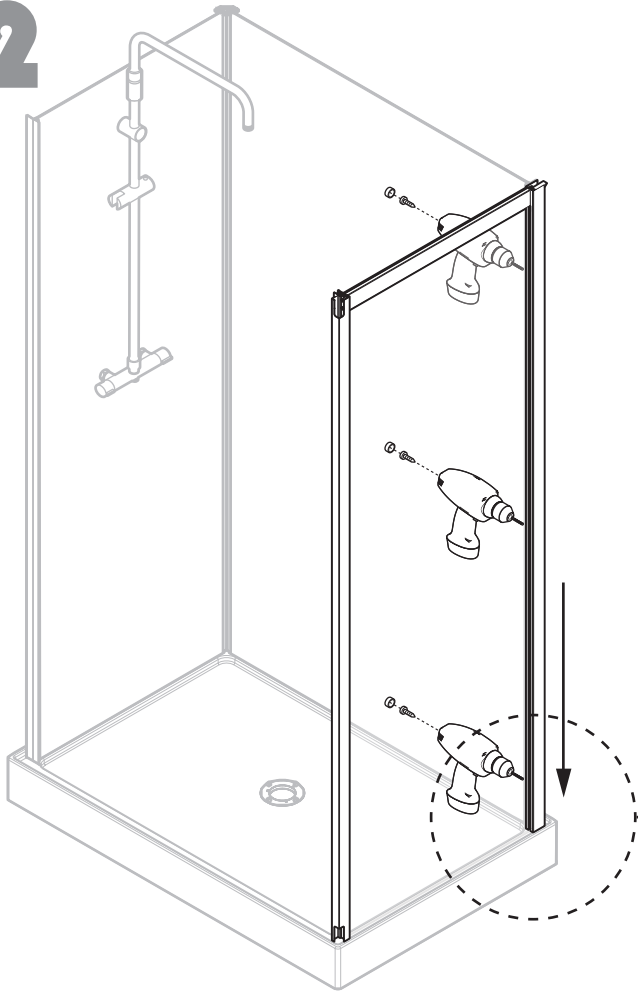

x3

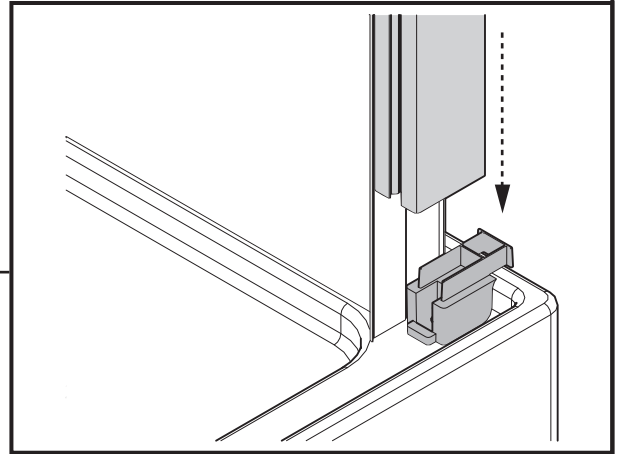
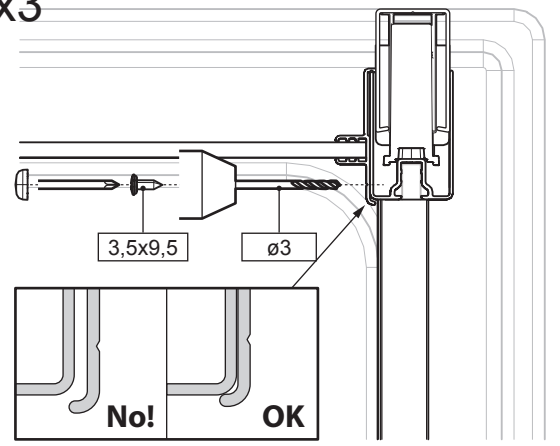

C3

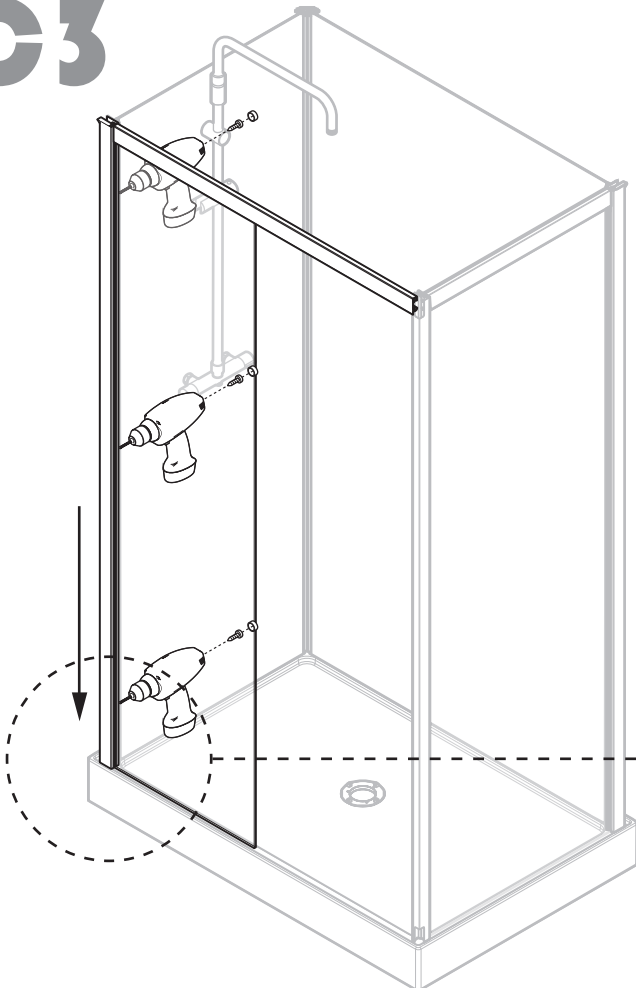

x3

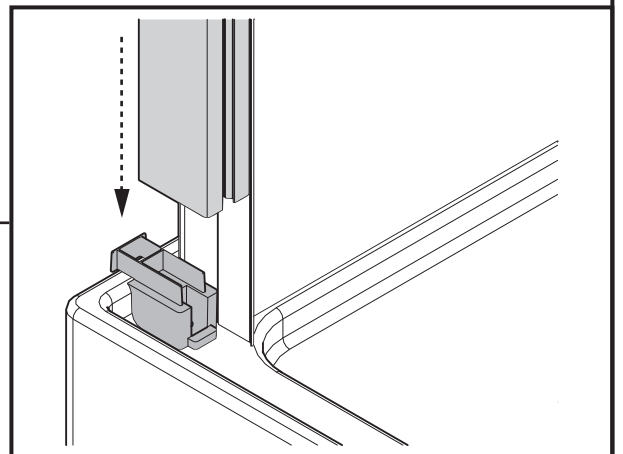
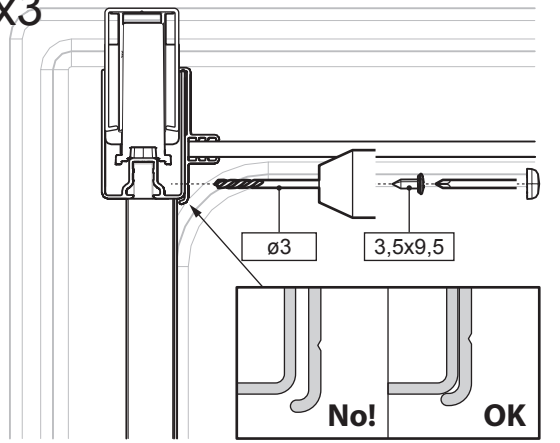

C4

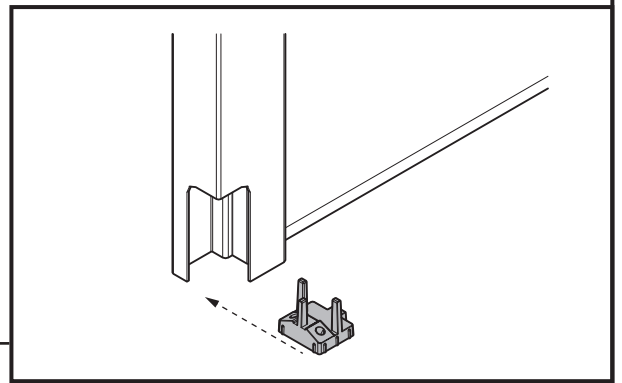
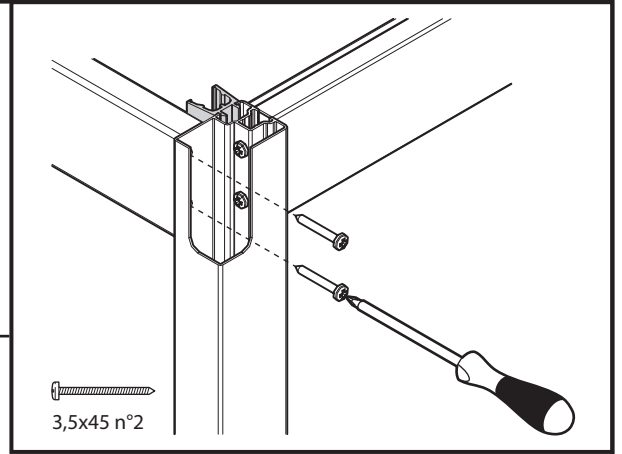
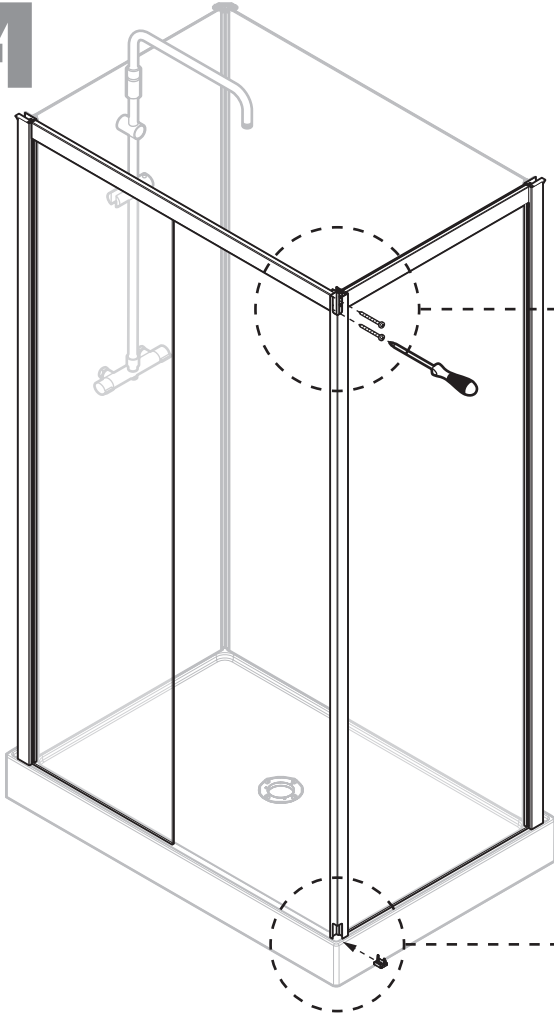

C5

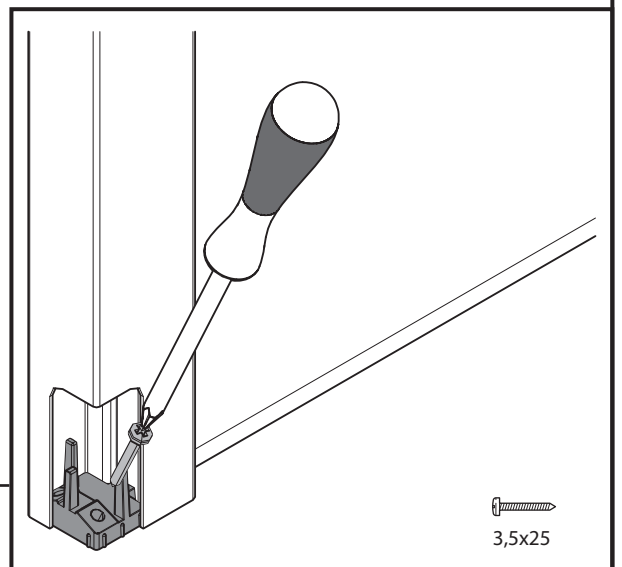
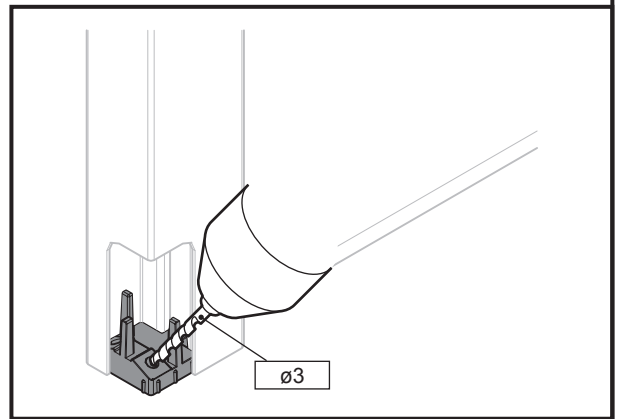
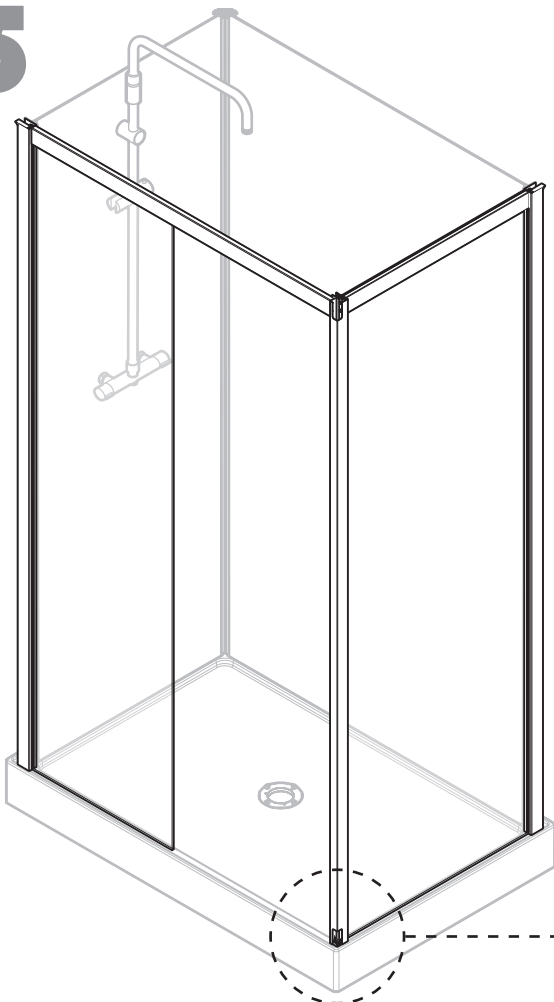

C6

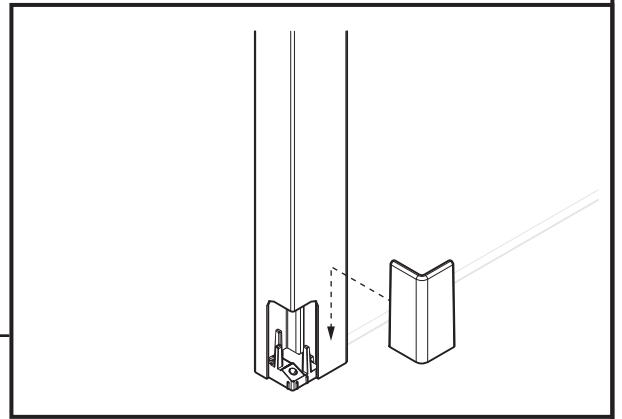
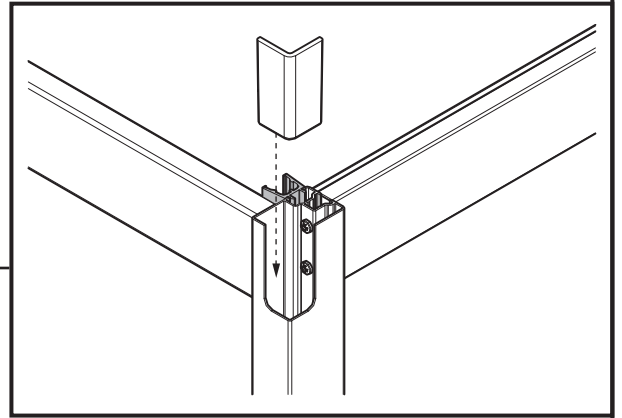
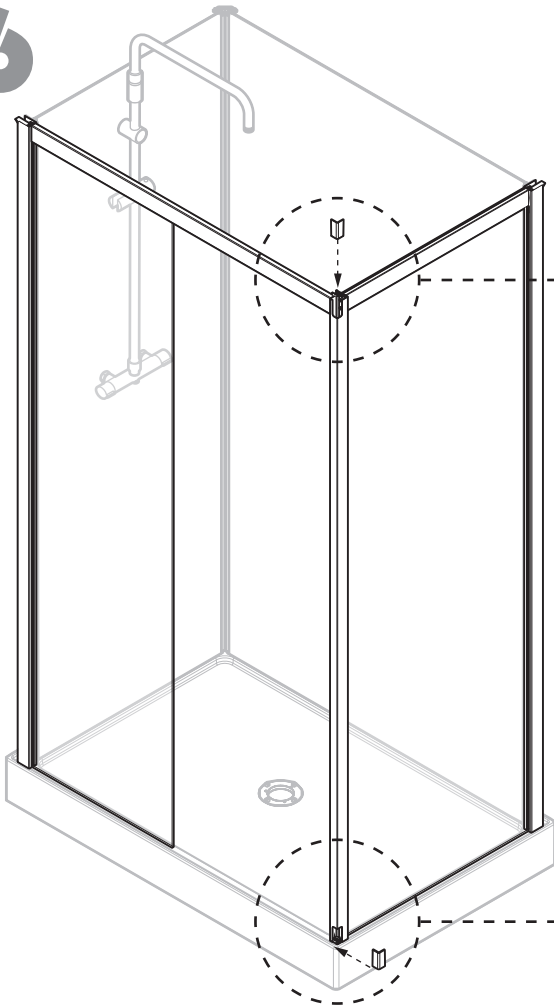

C7

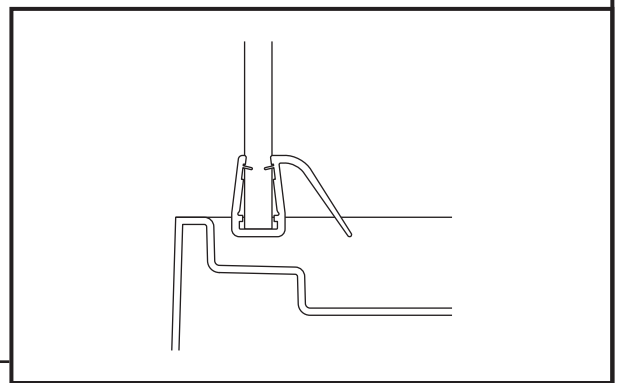
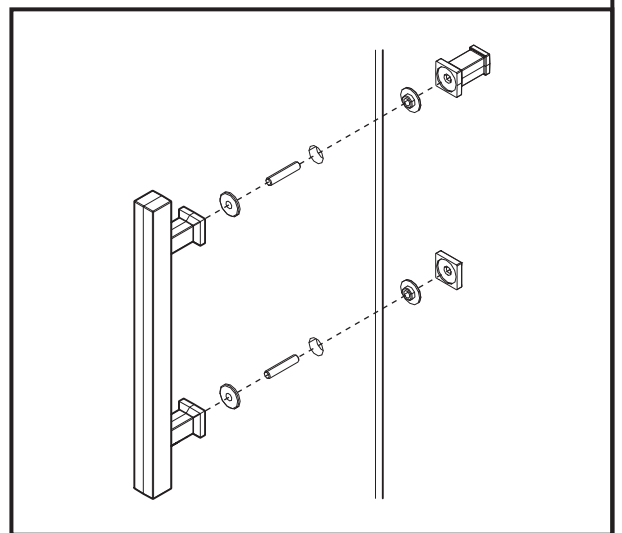
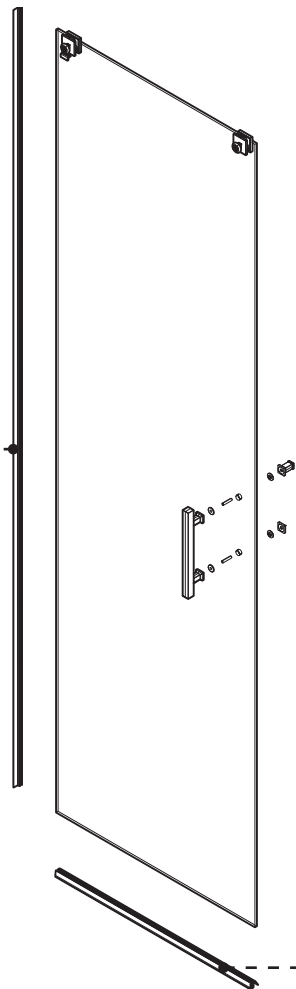
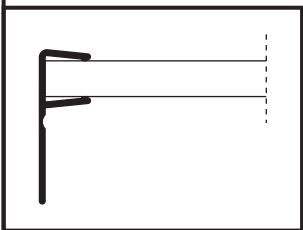

C8

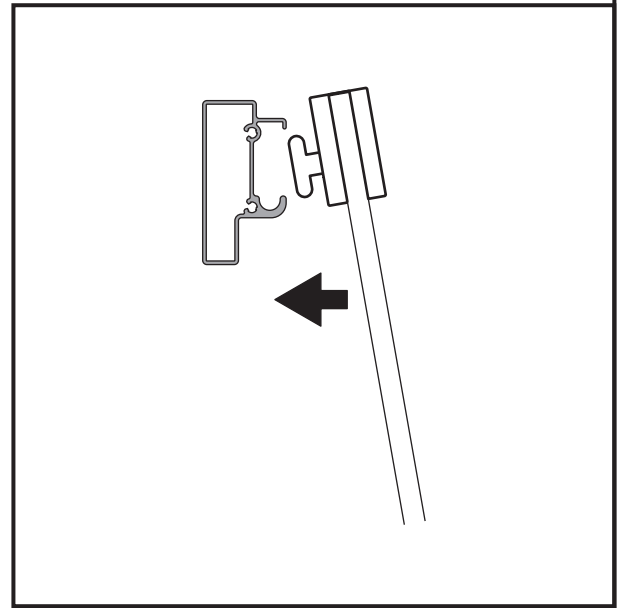

C9

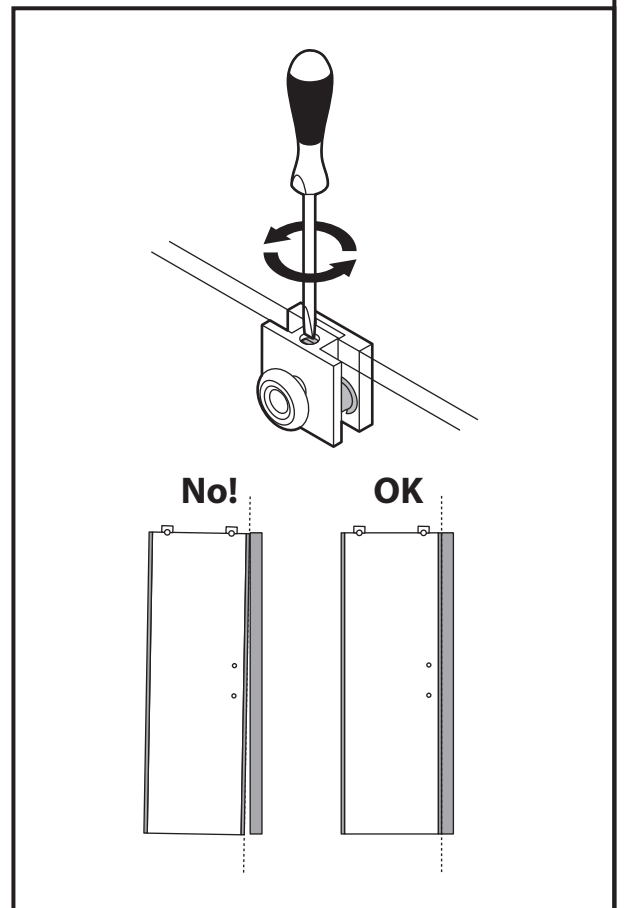
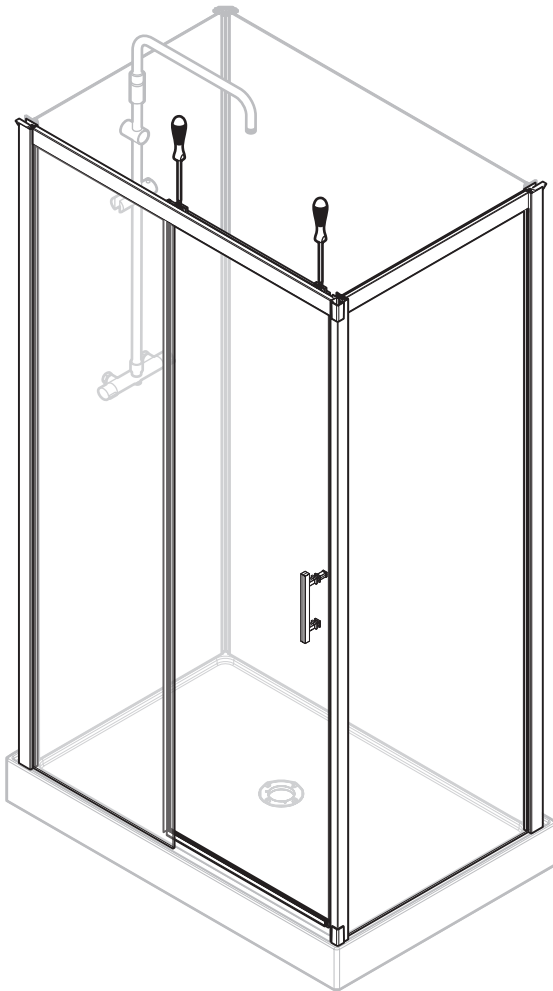

C10

x2

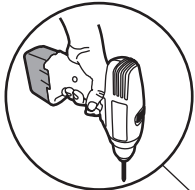

ø3 mm



3,5x13

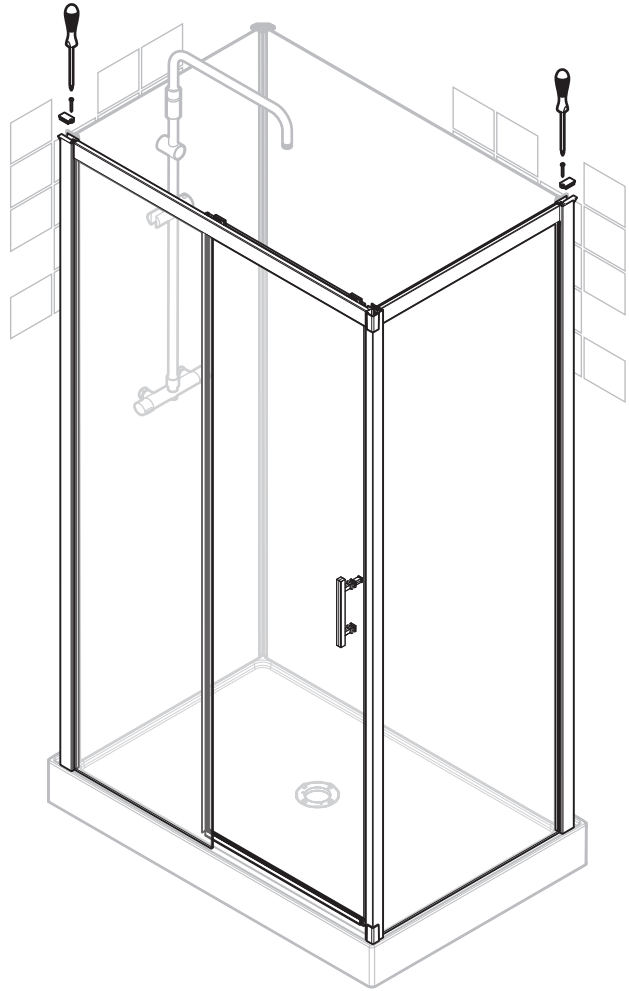
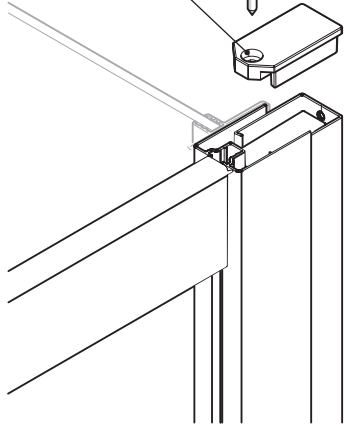

D

R 90

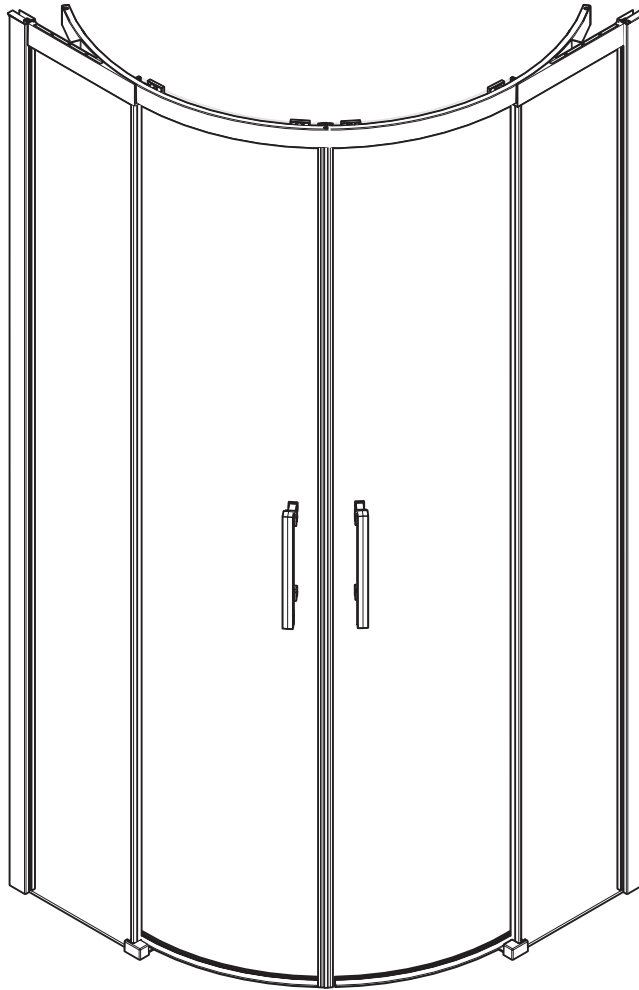

DI

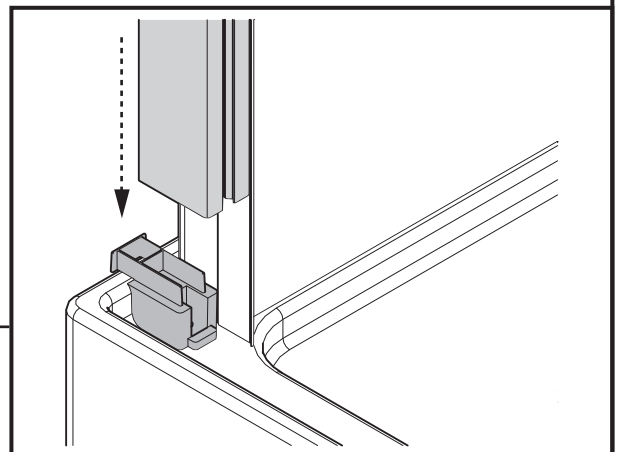
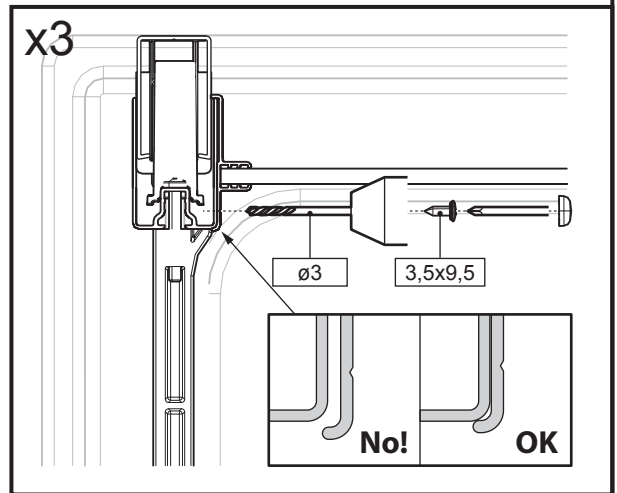
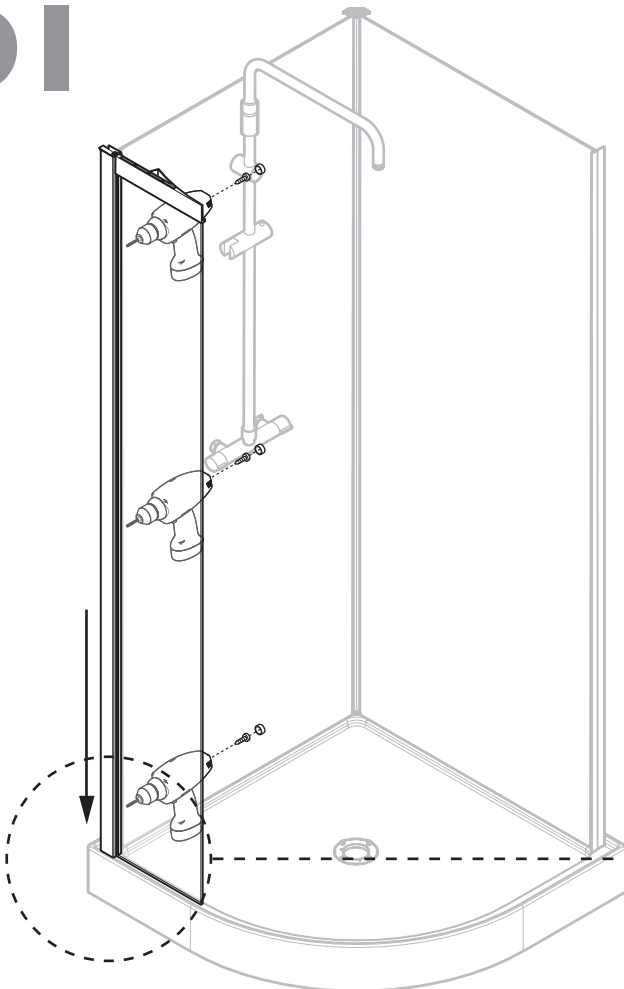

D2

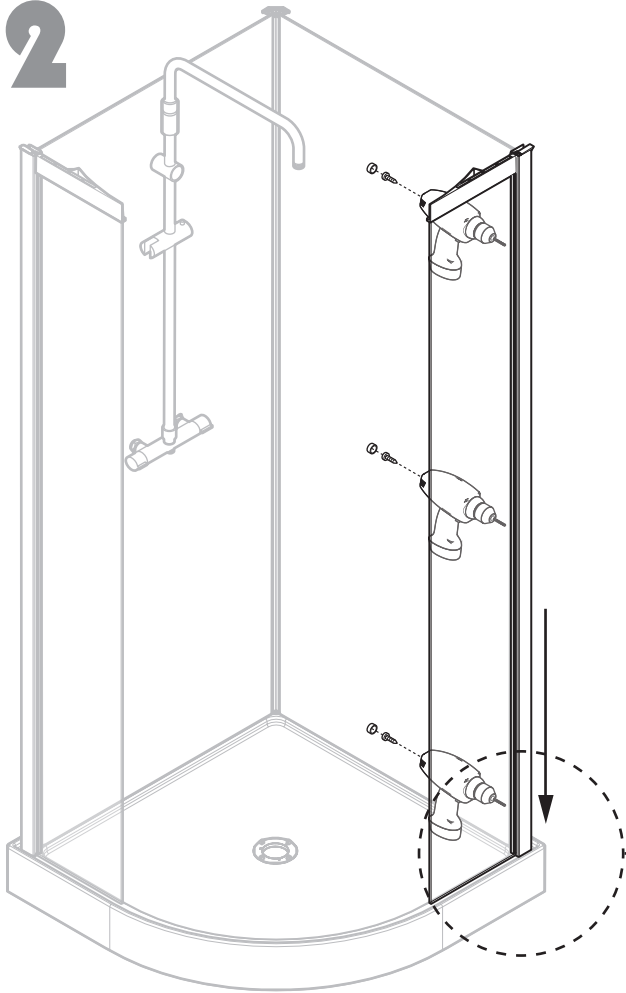

x3

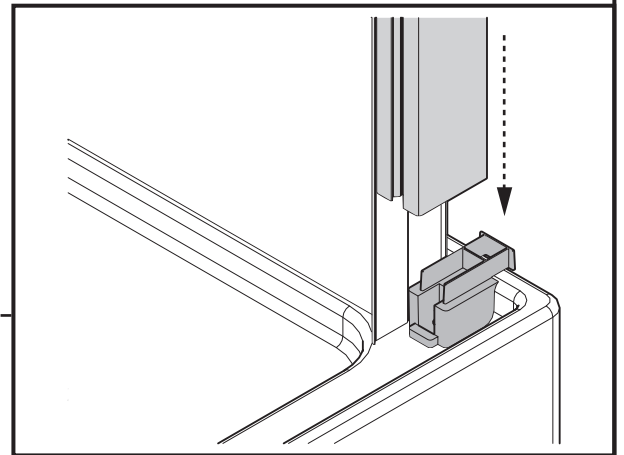
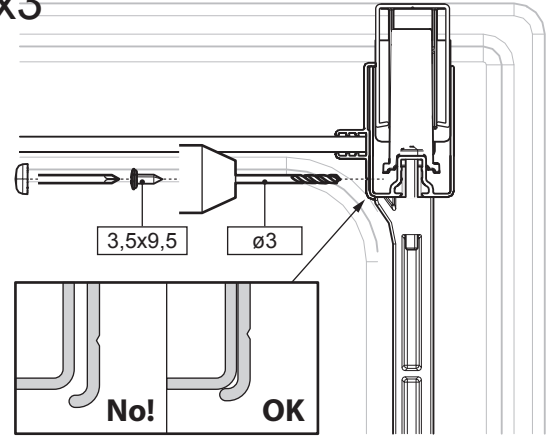

D3

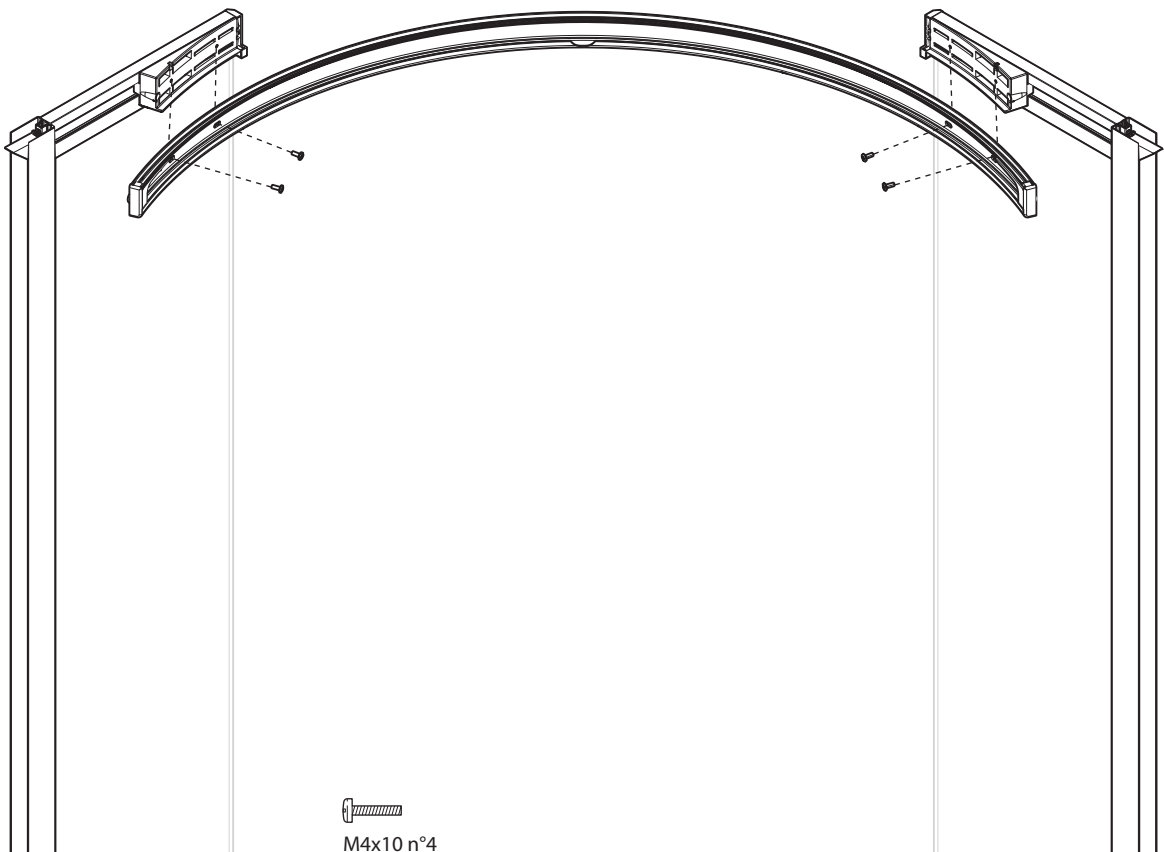

D4

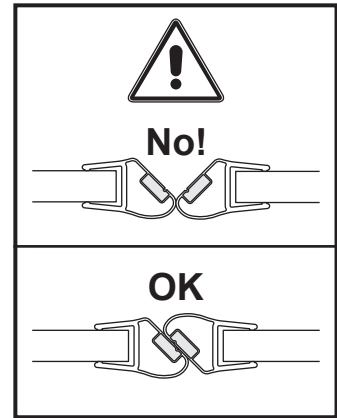
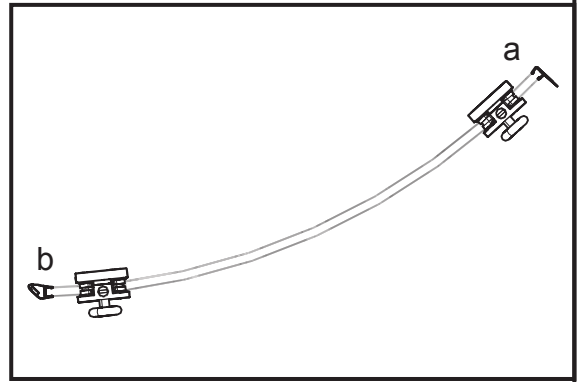
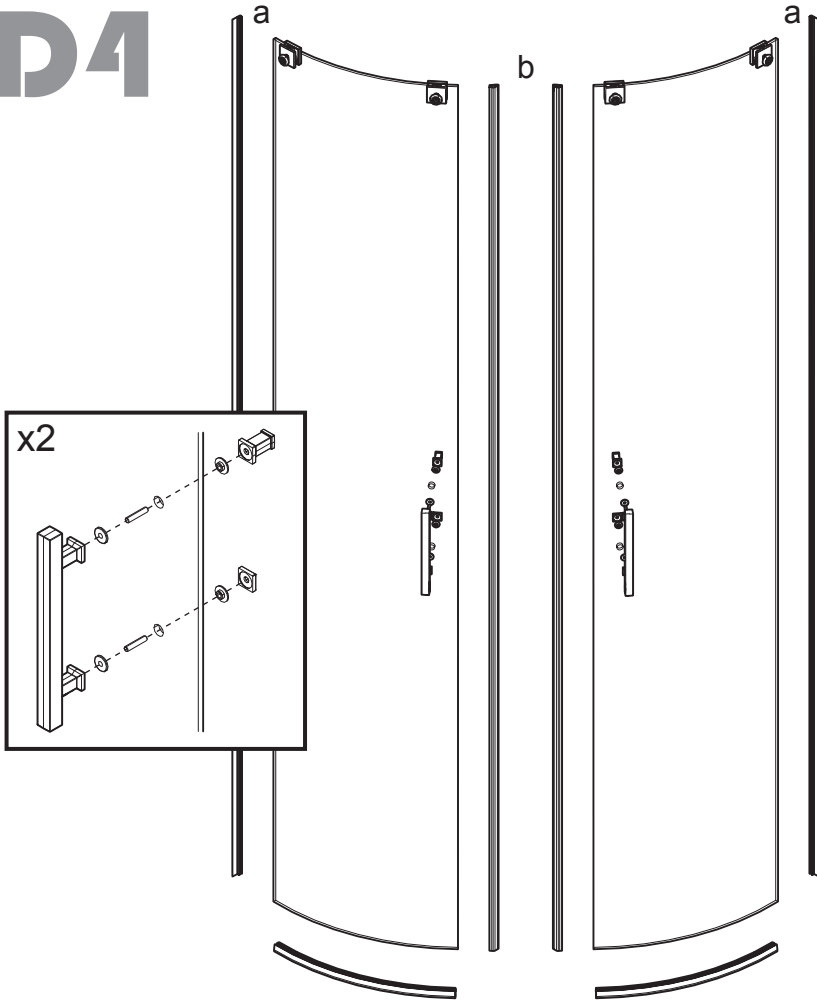

D5

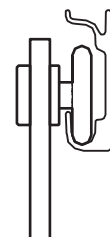
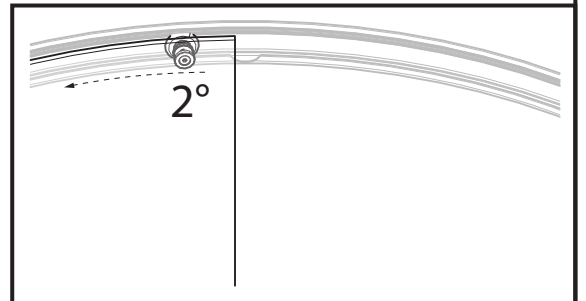
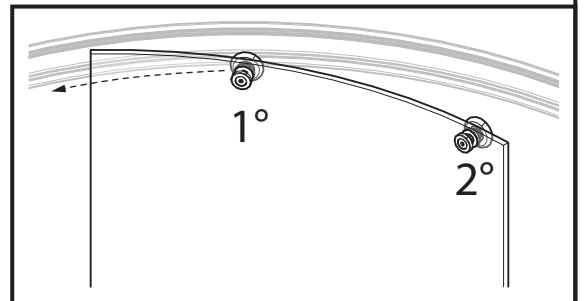
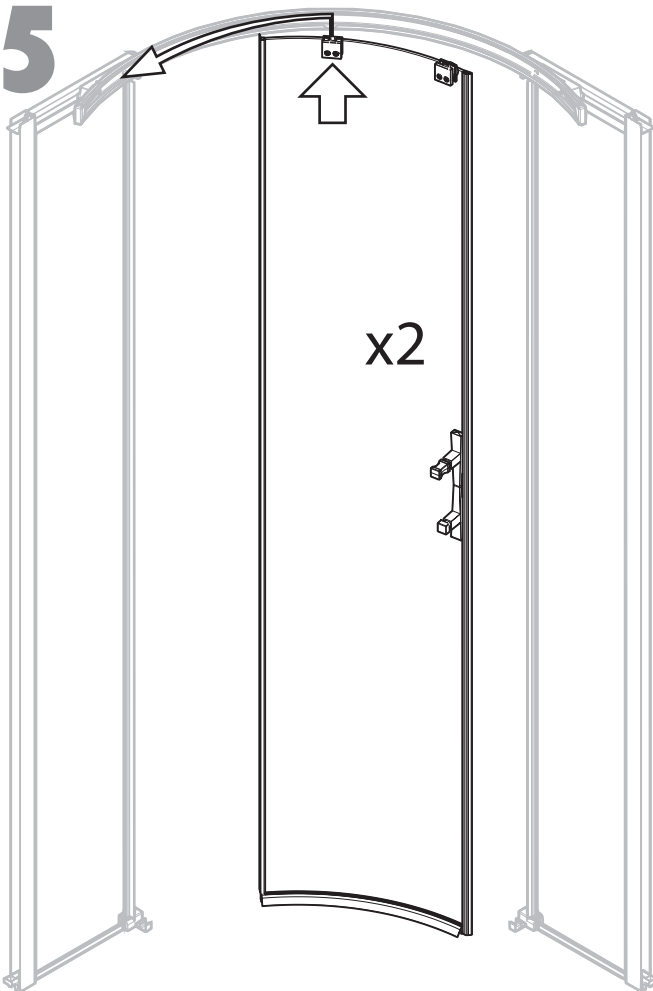

D6

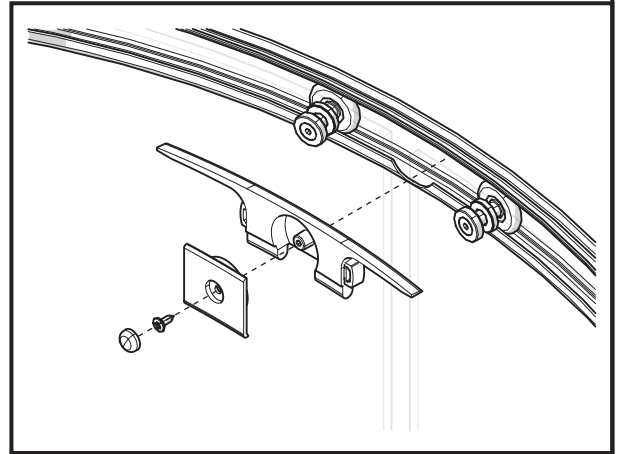
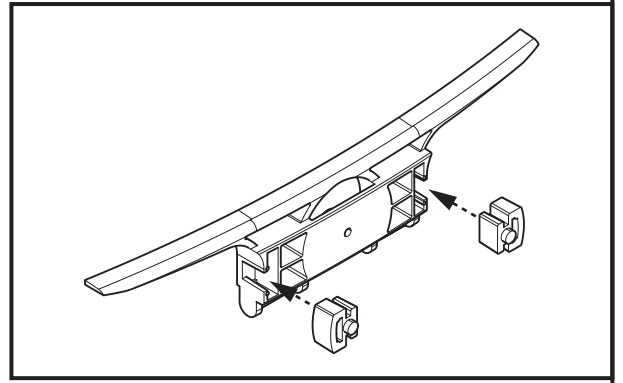
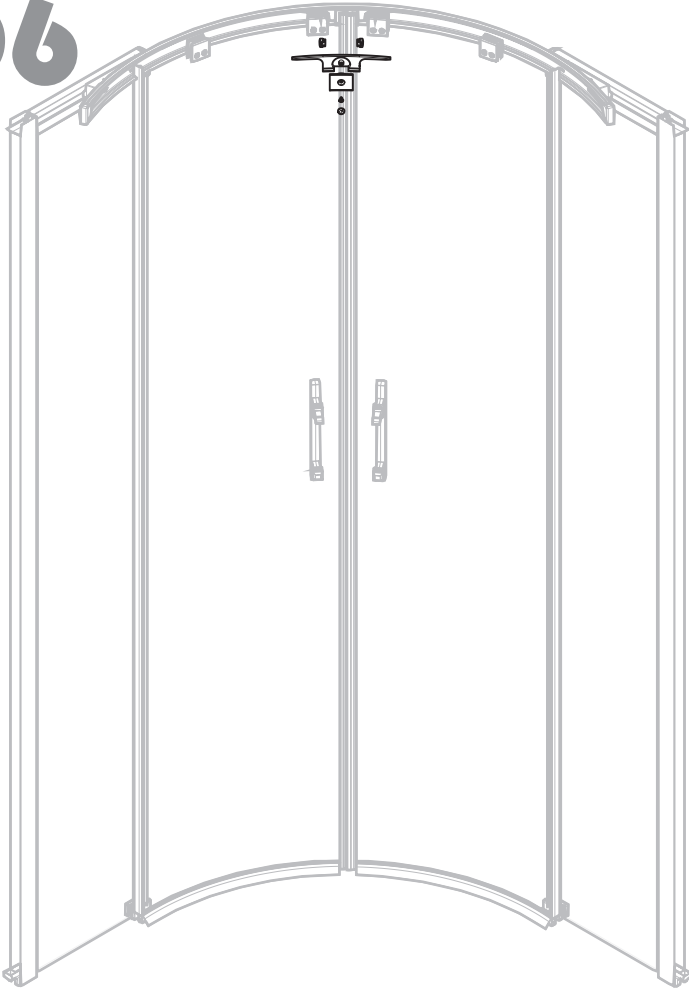

D7

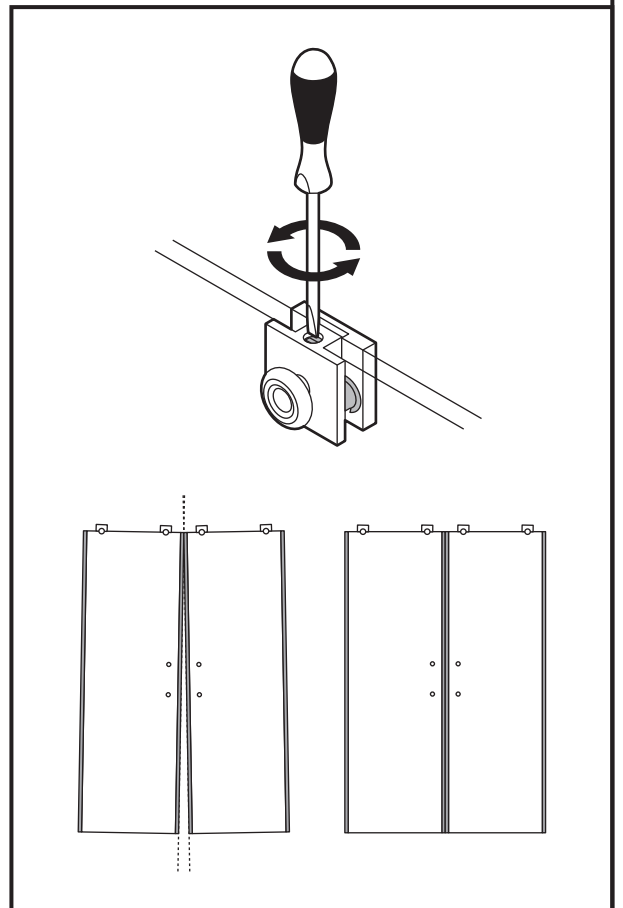
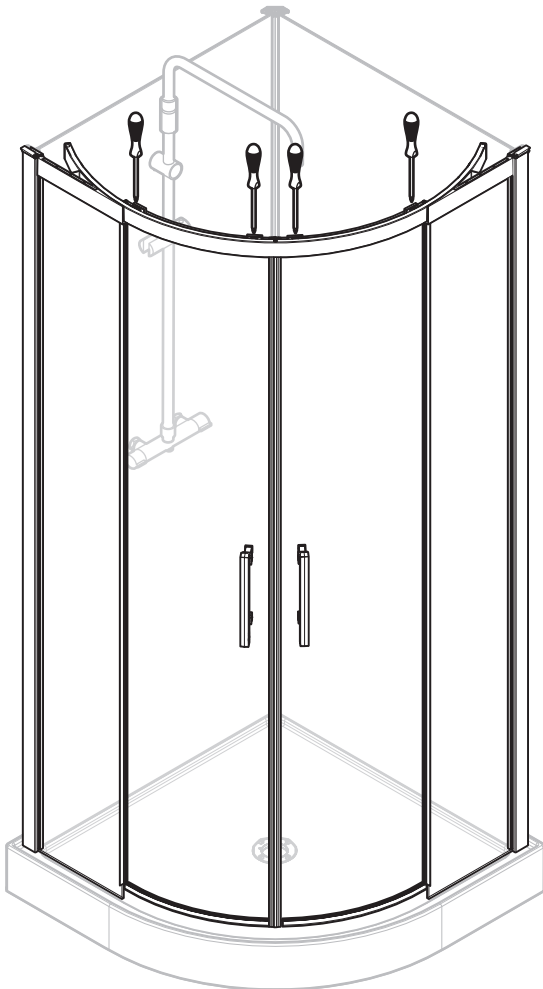

D8

x2

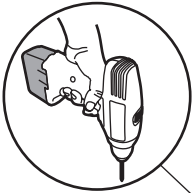

ø3 mm



3,5x13

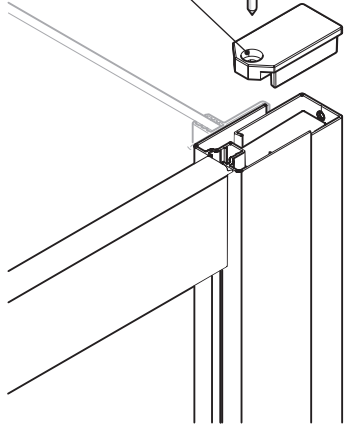

18

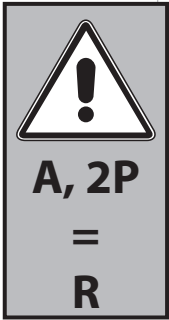

x2

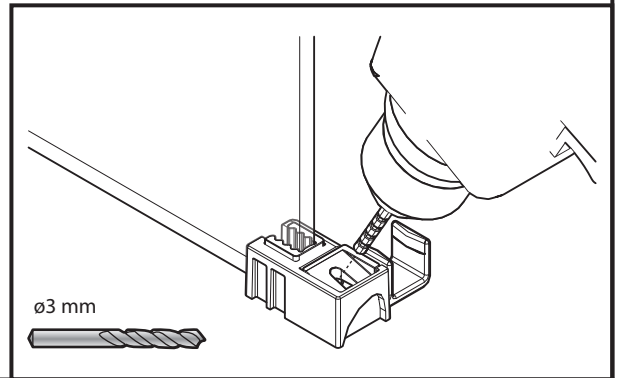
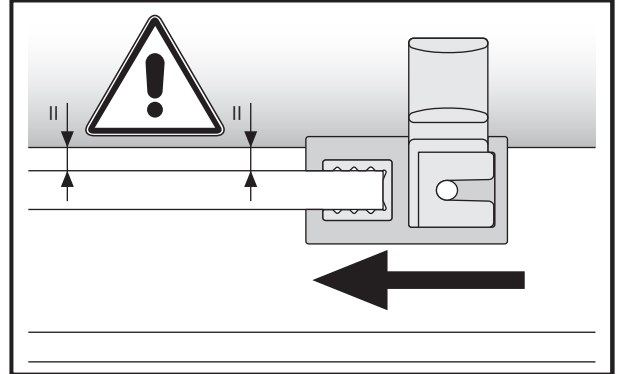
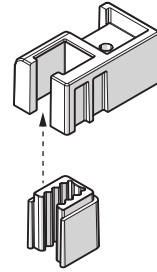

19

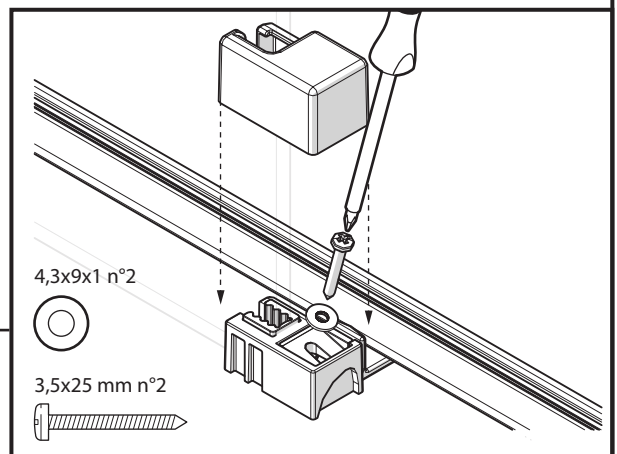
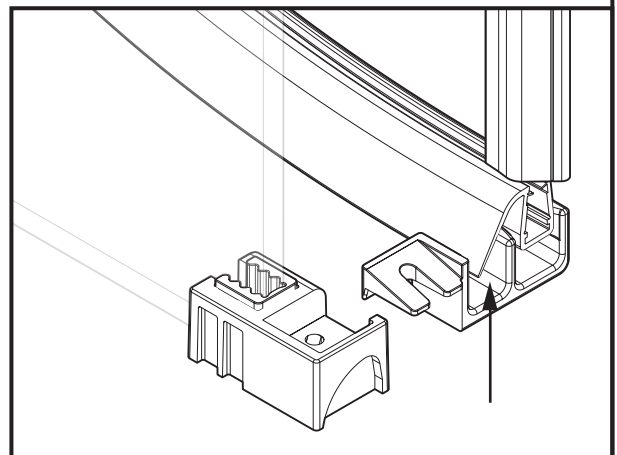
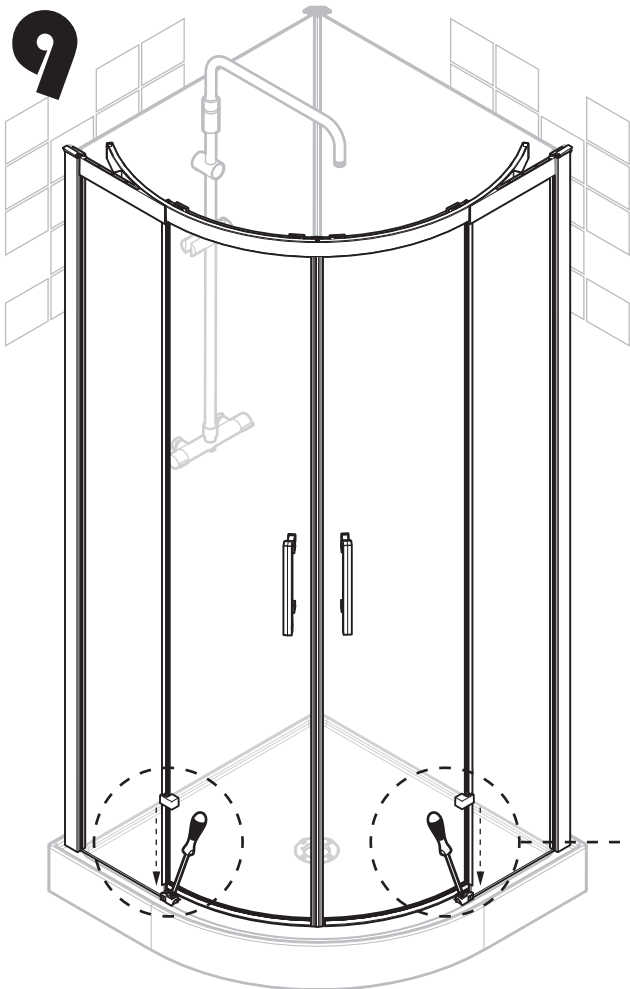

20

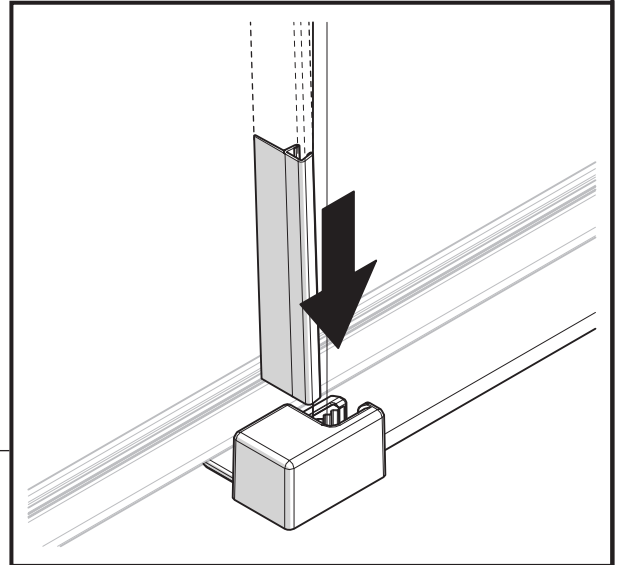
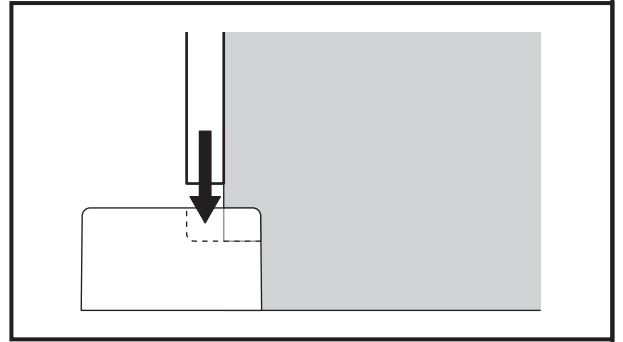
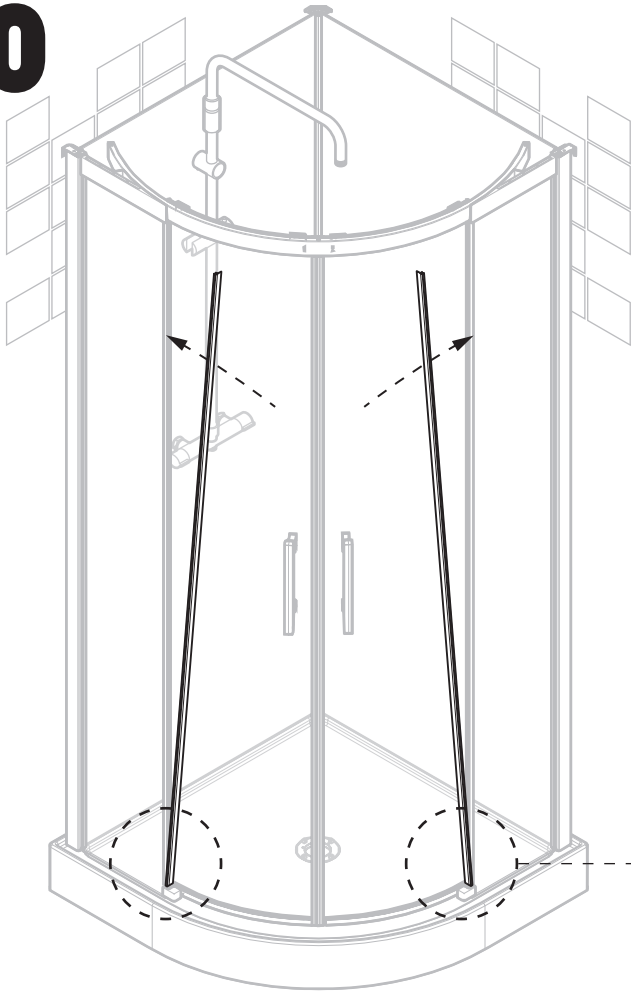

21

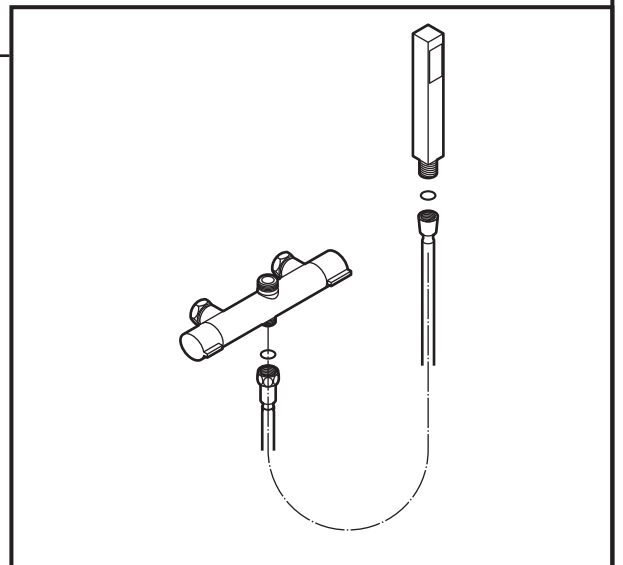
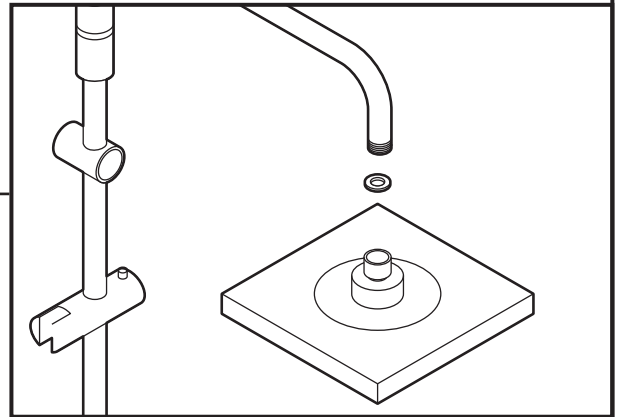
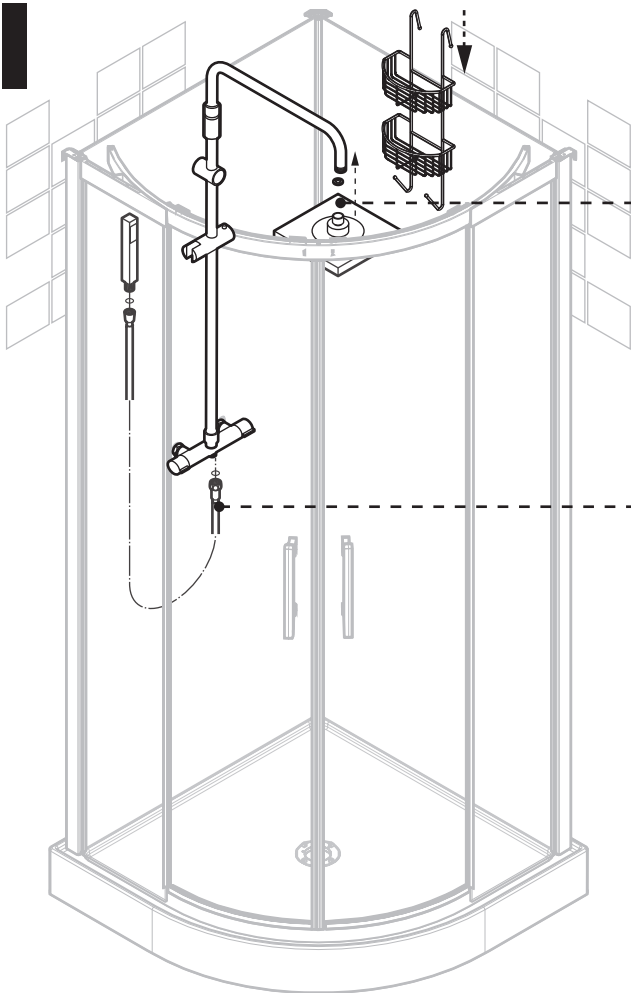

CERTIFICAT DE GARANTIE:

Sur le territoire italien, le produit est garanti conformément au décret du Président de la République italienne N. 224 du 24-05-1988 et dans les autres pays CEE, conformément à la directive CEE 85/374 en matière de responsabilité du fait des produits défectueux.

Le constructeur garantit ses produits contre tout vice de fabrication et défaut de matière pour une période de 24 mois à compter de la date d'achat à condition que les défauts en question soient constatés par des personnes autorisées par la société et que la date d'achat soit attestée par un reçu ou un ticket de caisse.

La garantie consiste dans la réparation et/ou le remplacement de pièces considérées comme défectueuses. Le remplacement complet du produit est exclu. La garantie exclut les consommables, le remplacement des pièces d'usure normale suite à l'utilisation du produit comme « les ampoules, les voyants, les fusibles, les pièces en verre, les miroirs, les pièces esthétiques, à moins que ceux-ci puissent être attribués à des défauts de fabrication et non à cause de négligence ou d'une mauvaise utilisation », toutes les pièces et composants qui sont défectueux ou endommagés en raison d'une négligence ou d'une utilisation inadéquate, d'une installation ou d'un entretien erronés, des interventions par des personnes non autorisées, des dommages dus au transport ou à d'autres circonstances non imputables à des défauts de fabrication dans le produit, comme des surtensions électriques, la foudre, l'électrolyse, la corrosion. Sont également exclus de la garantie toutes les pièces et composants du mitigeur et du groupe chaudière pouvant être endommagés ou usés en raison de causes imputables à la nature de l'eau ou des installations électriques et hydrauliques de l'habitation.

Avant toute installation, l'acheteur est tenu de s'assurer que le produit est bien intact et de contacter immédiatement le revendeur ou le centre d'assistance autorisé en cas de défauts. La prestation de garantie n'aura lieu que sur présentation du document attestant la date d'achat.

Tous les frais d'interventions n'ayant aucun rapport avec un vice de fabrication ou ayant pour but d'illustrer l'utilisation du produit sont à la charge de l'acheteur. Les réparations ou les modifications effectuées par des personnes non autorisées par le constructeur ne sont pas couvertes par la garantie et entraînent l'annulation immédiate de la période de garantie restante.

Le constructeur décline toute responsabilité en cas de dommages directs ou indirects causés aux personnes, animaux, choses et dus au non-respect des instructions du manuel de montage, utilisation et entretien, fourni avec le produit.

En cas de litige, seul le tribunal de Mantoue est compétent.

⚠ Dans tout le manuel, le pictogramme indiqué ci-contre signale toujours des instructions importantes ou bien liées à la sécurité d'utilisation du produit.

IMPORTANT:

avant de commencer à monter le produit, lire très attentivement toutes les instructions. S'assurer que l'emballage contient toutes les pièces nécessaires au montage et que celles-ci ne sont pas défectueuses, enlever le film transparent de protection (là où il y en a un). Avant d'effectuer l'installation définitive de la cabine de douche, il est recommandé de faire un essai préliminaire en laissant fonctionner l'appareil pendant quelques minutes pour vérifier s'il n'y a pas de fuites d'eau ou des dégâts à la suite de chocs subis pendant le transport et la manutention. Il est conseillé de confier l'installation à des techniciens qualifiés.

N.B.: Effectuer l'installation uniquement après avoir fini le sol et les murs.

Conserver la notice du produit et la facture/ticket de caisse pour toutes réclamations.

Les illustrations et les dessins qui figurent dans cette notice sont purement indicatifs. Le fabricant se réserve la faculté d'apporter des modifications et des variations à ses produits sans préavis.

ATTENTION!

La dureté de l'eau ne doit pas dépasser 20° F (degrés français).

La teneur en chlore ne doit pas dépasser 100 mg par litre.

Démontage de la robinetterie:

En cas de formations de calcaire provoquant un mauvais fonctionnement de la robinetterie (fig. A/B/C...), démonter les pièces. Il est recommandé de tremper la cartouche dans du vinaigre de vin normal jusqu'à ce que le calcaire disparaisse.

Pour que le mitigeur thermostatique fonctionne correctement, prévoir un générateur de vapeur ou un chauffe-eau ayant un débit d'au moins 6/7 litres d'eau par minute à une température de 60/65°C.

NETTOYAGE DE LA CABINE DE DOUCHE:**ENTRETIEN**

La cabine est réalisée avec des pièces acryliques et ne doit être nettoyée qu'avec un détergent liquide non agressif et une éponge ou chiffon doux. Pour empêcher la formation de traces de calcaire, essuyez la cabine après utilisation avec une peau de chamois ou un chiffon en microfibre qui nettoie à fond sans laisser de résidus. Eliminer toute trace de calcaire en utilisant des produits détergents anticalcaires spécifiques. Pour rendre luisant la surface acrylique utiliser un "Polish" ordinaire de carrossier.

IL NE FAUT PAS UTILISER DE DETERGENTS ABRASIFS, ALCOOL, SUBSTANCES A BASE D'ALCOOL, ACETONE OU AUTRES SOLVANTS.

INCONVENIENTS:

Avant d'appeler l'Assistance Technique, vérifier que:

- les flexibles sont raccordés correctement et qu'ils n'ont pas été pliés pendant le positionnement final de la cabine;
- le circuit principal produit régulièrement de l'eau froide et de l'eau chaude à la température souhaitée;
- les canalisations ont été purgées avant l'installation;
- l'alimentation de réseau est bien raccordée au hammam et le voyant vert de réseau est allumé sur le tableau.

Si, malgré nos conseils et une utilisation appropriée, la cabine ne fonctionne toujours pas correctement, contacter directement le centre d'assistance technique (voir le numéro de téléphone sur la brochure ci-jointe).

ELIMINATION DU PRODUIT:

Pour éliminer le produit et ses pièces, respectez les réglementations locales en matière d'élimination des déchets. Sur le territoire italien, le Décret Loi n° 22 du 5 février 1997; dans les autres pays de la CEE, les directives 91/156/CEE, 91/689/CEE et 94/62/CE.

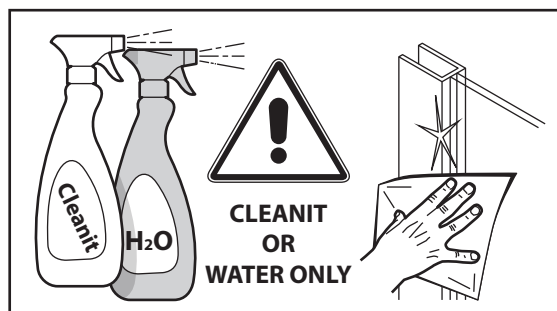

ENGLISH

PRODUCT GUARANTEE:

The product is guaranteed as per Italian Presidential Decree 224 of 24/05/1988 in Italy and the rest of the EU and as per CEE Directive 85/374 in terms of product liability. The Manufacturer guarantees its products against manufacturing and material defects – provided these are confirmed by the authorised personnel of the Company – for a period of 24 months from the purchase date, as indicated by the receipt or invoice.

The guarantee covers repairs to and/or replacement of the parts considered to be faulty. The guarantee does not cover complete replacement of the product. The guarantee does not cover expendable materials, the replacement of pieces subject to normal wear as a result of use, such as “lights, warning lights, fuses, glass parts, mirrors and decorative parts unless these are faulty due to production defects and not due to neglect or improper use”, any parts and components which are faulty or damaged due to negligence or carelessness during use, incorrect installation or maintenance, operations carried out by non-authorised personnel, and damage caused during transport or any other circumstances not due to product manufacturing defects, such as sudden power hikes, lightning, electrolysis and corrosion. Furthermore, the guarantee does not cover all the parts and components of the mixer and the boiler unit damaged or worn due to causes deriving from and attributable to the nature of the water or electrical or water supply systems of the home.

The Purchaser must check that the product is not damaged in any way before installation and must contact the agent or authorised assistance centre immediately if any faults are detected. The guarantee will only be applied on presentation of a document indicating the purchase date.

In the event of operations without proven defects or to illustrate how to use the product, all the expenses are sustained by the Purchaser. Any repairs or modifications carried out by personnel not authorised by the Manufacturer will not be covered by the guarantee and will render the remaining guarantee period immediately null and void.

The Manufacturer is not responsible in any way for any direct or indirect damage caused to persons, animals or things due to failure to comply with all the regulations in the installation, instruction and maintenance manual supplied with the product.

Any disputes will be dealt with exclusively by Mantova Italy, Law Court.

 **This symbol indicates important product instructions or important safety information.**

IMPORTANT:

Before you start to assemble and install the product, carefully read through all the instructions. Unpack the components and check that nothing is missing and that there are no damaged or faulty components, remove the transparent protective film. Before you install the shower cubicle in its final position, perform a test run. Run the unit for several minutes and check for water leaks and any damage caused during transport and handling. This product should be installed by suitably skilled personnel.

N.B.: This product is designed for installation on finished walls and floors.

Warranty claims must be produced with the purchase invoice and the product assembling instructions.

The drawings and illustrations in this manual are provided for information purposes only.

The manufacturer reserves the right to make changes and improvements without prior notice.

WARNING!

Water hardness must never exceed 20° FR (french degrees).

The chlorine contained must never exceed 100 mg per litre.

Dismantling the shower valves:

In the event of the formation of lime scale and a resulting malfunctioning of the shower valves, dismantle the parts (fig. A/B/C...). We recommend you immerse the cartridge in normal vinegar until it is completely lime scale-free.

To ensure correct operation of the thermostatic mixer, the unit must be supplied from a boiler or a water heater providing 6 to 7 litres per minute of water at a temperature of 60/65°C.

CLEANING THE SHOWER UNIT:

CARING FOR YOUR CUBICLE

The cubicle panels are made with acrylic parts and must be cleaned using a liquid detergent and a soft cloth or sponge. Use a good quality household liquid detergent.

To prevent scale deposits, wipe dry using a chammy leather or a soft lint-free cloth that removes stubborn deposits without leaving traces. Limescale deposits may be removed using specific detergent products. To restore shine to the acrylic surface polish with an ordinary wax polish such as car wax. **DO NOT USE ABRASIVE CLEANERS, ALCOHOL OR ALCOHOL BASED PRODUCTS, ACETONE OR OTHER SOLVENTS.**

TROUBLESHOOTING:

Before calling the Service Centre, check that:

- The hoses are properly connected and not kinked.
- Hot and cold water is being correctly delivered to the wall fittings.
- The water supply system was bled before the shower unit was installed.
- The mains power supply is reaching the steam generator and the green Power On LED on the control panel is lit.

If you have followed the instructions and the shower still does not work, call the nearest Service Centre. The telephone numbers of authorised service centres are given in the enclosed list.

WASTE DISPOSAL:

To dispose of the shower unit or any part of it, follow local waste disposal regulations. In Italy, Legislative Decree No. 22 of 5 February 1997 applies. In other EU countries, the subject is governed by directives 91/156/EEC, 91/689/EEC and 94/62/EC.



GARANTIE:

Auf italienischem Staatsgebiet wird für das Produkt gemäß D.P.R. Nr.224 vom 24.05.1988 Garantie gewährt, und in den übrigen EWG-Ländern gemäß Richtlinie 85/374/EWG im Rahmen der Haftbarkeit für Schäden, die auf Produktmängel zurückzuführen sind.

Die vom Hersteller gewährte Garantie umfasst Produktions- und Materialfehler lediglich, wenn diese von vom Unternehmen befugtem Personal festgestellt werden, und gilt 24 Monate ab Datum des Erwerbs und unter Vorlage der Quittung bzw. des Kassenzettels.

Die Garantie umfasst die Reparatur und/oder den Ersatz der als defekt betrachteten Teile. Die Garantie umfasst nicht den kompletten Ersatz des Produkts. Ausgeschlossen von der Garantie sind die Verschleißmaterialien, der Ersatz aller infolge der Produktverwendung einem normalen Verschleiß unterliegenden Teile wie "die Lampen, Kontrollleuchten, Sicherungen, Glasteile, Spiegel und Dekorteile, es sei denn, die nachgewiesenen Mängel sind auf Fertigungsfehler und nicht auf Nachlässigkeit oder unsachgemäßen Gebrauch zurückzuführen. Ferner von der Garantie ausgeschlossen sind alle Teile und Bauteile, die sich aufgrund von Nachlässigkeit, nachlässigem Gebrauch, fehlerhafter Installation bzw. Wartung, Eingriffen seitens unbefugtem Personal oder Transportschäden bzw. Schäden, die nicht auf Fertigungsmängel, sondern beispielsweise auf Stromschwankungen, Blitzschlag, Elektrolyse, Korrosion zurückgehen, als mangelhaft oder beschädigt erweisen sollten. Ebenfalls von der Garantie ausgeschlossen sind alle Teile und Bauteile des Mischers und des Kesselaggregats, die sich wegen Wasserschäden bzw. Schäden, die durch die Strom- bzw. Wasserversorgungsanlage der Wohnung bedingt sind, als beschädigt oder abgenutzt herausstellen sollten.

Der Käufer muss das Produkt vor der Installation auf einwandfreien Zustand prüfen und im Falle von Unregelmäßigkeiten den Händler bzw. eine autorisierte Kundendienststelle benachrichtigen. Die Garantie wird nur unter Vorlage eines Belegs geleistet, aus dem das Erwerbsdatum hervorgeht.

Wird der Kundendienst gerufen, ohne dass Produktmängel nachgewiesen werden bzw. zur Einweisung in den Gebrauch des Produkts, gehen alle Kosten zulasten des Käufers. Reparaturen bzw. Änderungen, die von nicht vom Hersteller autorisiertem Personal ausgeführt werden, geben keinen Anspruch auf Kostenerstattung und führen zum sofortigen Verfall der Garantie.

Der Hersteller übernimmt keine Haftung für direkte bzw. indirekte Schäden an Personen, Haustieren bzw. Sachen, wenn diese Schäden auf die Nichtbeachtung der Vorschriften der Installations-, Gebrauchs- und Wartungsanleitung zurückzuführen sind, die das Produkt begleitet.

Im Falle von Rechtsstreitigkeiten ist einziger Gerichtsstand Mantua.

⚠ Dieses Symbol wird in vorliegendem Handbuch immer dann verwendet, wenn wichtige oder der Produktsicherheit dienende Hinweise erteilt werden.

WICHTIG:

Vor Beginn der Montage sollten Sie sämtliche Anweisungen aufmerksam lesen. Überprüfen sie, ob die Packung mit den Bestandteilen für die Montage vollständig ist, und dass diese nicht offensichtlich beschädigt sind, falls vorhanden, die durchsichtige Schutzfolie abnehmen. Vor der endgültigen Installation der Duschkabine wird eine vorsorgliche Kontrolle der Funktionstüchtigkeit der Einrichtung empfohlen. Dazu die Einrichtung einige Minuten lang betreiben und auf undichte Stellen bzw. Schäden prüfen, die eventuell durch den Transport verursacht wurden. Wir empfehlen, die Installation von Fachpersonal vornehmen zu lassen.

ANMERKUNG: Die Installation darf erst nach Fertigstellung von Fußboden und Wänden zu erfolgen.

Im Fall von Reklamation, die Rechnungsanlage zusammen mit den Montageanleitungen vorlegen.

Die im Handbuch enthaltenen Abbildungen und Zeichnungen dienen nur der Veranschaulichung.

Die Garantie behält sich das Recht vor, Änderungen daran vorzunehmen.

ACHTUNG!

Die Wasserhärte darf niemals 20° fr.H. (französische Härtegrade) überschreiten.

Der Chlorgehalt darf nicht mehr als 100 mg pro Liter betragen.

Ausbau der Armaturen:

Falls die Funktion der Armaturen durch Kalkablagerungen beeinträchtigt wird, müssen diese Teile ausgebaut werden (Abb. A/B/C...). Wir empfehlen, die Kartusche in normalen Weinessig einzutauchen, bis sich die Kalkablagerungen vollständig aufgelöst haben.

Für die korrekte Funktion des Thermostatmischers ist ein Boiler bzw. ein Durchlauferhitzer mit einer Wasserausgabe von mindestens 6/7 Litern Wasser pro Minute bei einer Temperatur von 60/65°C nötig.

REINIGUNG DER DUSCHWAND:

WARTUNG

Teile der Wanne bestehen aus Acryl. Zur Reinigung muß aus diesem Grund ein flüssiges Reinigungsmittel mit einem Schwamm bzw. einem weichen Tuch verwendet werden. Es werden handelsübliche Markenprodukte empfohlen. Zur Verhinderung von Kalkablagerungen sollte die Wanne nach dem Gebrauch mit einem Fensterleder bzw. einem Mikrofasertuch ausgewischt werden. Eventuelle Kalkablagerungen werden mit speziellen kalklosenden Produkten entfernt. Um glänzende Oberflächen wieder zu erhalten, eine normale Autopolitur verwenden.

KEINESFALLS SCHEUERMITTEL, ALKOHOL, ALKOHOLHALTIGE STOFFE, ACETON BZW. ANDERE LÖSUNGSMITTEL VERWENDEN.

STÖRUNGEN:

Bevor Sie den Kundendienst verständigen, prüfen Sie bitte folgendes:

- Schläuche richtig angeschlossen und nicht geknickt.
- Kalt- und Warmwasser gelangt ordnungsgemäß zu den entsprechenden Wandanschlüssen.
- Sicherstellen, dass die Leitungen vor der Installation entlüftet wurden.
- Sauna ordnungsgemäß mit Strom versorgt und grüne Netzkontrolleuchte auf der Schalttafel leuchtet.

Sollte die Funktionseinheit trotz unserer Ratschläge und des ordnungsgemäßen Gebrauchs immer noch nicht funktionieren, wenden Sie sich bitte an die nächste Kundendienststelle, deren Telefonnummer Sie dem beiliegenden Blatt entnehmen können.

ABFALLENTSORGUNG:

Die Entsorgung des Produkts und seiner Bestandteile muß unter Beachtung der ortsüblichen Gesetzesvorschriften für die Abfallbehandlung erfolgen. In Italien: D.L. Nr. 22 vom 5 Februar 1997. In den anderen Ländern der EU: Richtlinie 91/156/EWG, 91/689/EWG und 94/62/EG.



NEDERLANDS

GARANTIECERTIFICAAT:

Op het product wordt garantie verleend volgens de voorschriften van het D.P.R. N.224 van 24/05/1988 voor het Italiaanse rechtsgebied, en voor de andere landen in de EU volgens de Europese richtlijn 85/374 inzake productaansprakelijkheid.

De fabrikant garandeert zijn producten tegen materiaal- en productiefouten - alleen indien deze worden vastgesteld door personeel dat door het bedrijf is geautoriseerd - gedurende een periode van 24 maanden vanaf de aankoopdatum die blijkt uit het betaalbewijs of de kassabon.

De garantie bestaat uit de reparatie en/of vervanging van de onderdelen waarvan wordt geconstateerd dat ze defect zijn. Een volledige vervanging van het product is uitgesloten. Buiten de garantie vallen de verbruiksmaterialen, de vervanging van onderdelen die onderhevig zijn aan normale slijtage door gebruik van het product zoals de lampen, waarschuwingslampjes, zekeringen, glazen onderdelen, spiegels, sieronderdelen, tenzij blijkt dat de defecten te wijten zijn aan productiefouten en niet aan nalatigheid of onbedoeld gebruik, alle onderdelen en componenten die defect blijken door nalatigheid of onachtzaamheid in het gebruik, onjuiste installatie of onderhoud, reparaties door niet-geautoriseerd personeel, schade door transport of omstandigheden die niet terug te leiden zijn op fabricagefouten van het product zoals fluctuaties in de elektrische spanning, blikseminslag, elektrolyse, roestvorming. Verder vallen buiten de garantie alle onderdelen en componenten van de mengkraan en de keteleenheid die defect of versleten blijken door oorzaken die voortkomen uit en te wijten zijn aan de eigenschappen van het water en van elektrische en hydraulische voedingsinstallaties in huis.

De koper heeft hoe dan ook de plicht te controleren, voordat het geïnstalleerd wordt, of het product onbeschadigd is, en dient onmiddellijk contact op te nemen met de dealer of het erkende servicecentrum in het geval er afwijkingen worden geconstateerd. De koper kan zijn recht op garantie uitsluitend laten gelden als hij de aankoopdatum kan documenteren.

Bij tussenkomst zonder een geldig defect of met het doel het gebruik van het product toe te lichten, komen alle kosten ten laste van de koper. Reparaties of wijzigingen die worden verricht door personen die daartoe niet door de fabrikant zijn geautoriseerd, kunnen niet worden vergoed onder garantie, en doen de resterende garantieperiode onmiddellijk vervallen.

De fabrikant is niet aansprakelijk voor eventuele directe of indirecte schade of letsel aan personen, dieren of voorwerpen die te wijten is aan het niet naleven van de voorschriften in deze handleiding voor installatie, gebruik en onderhoud die bij het product wordt geleverd.

Voor eventuele geschillen is de Rechtbank van Mantua als enige bevoegd.

⚠️ Telkens wanneer u bij het lezen van deze handleiding dit symbool tegenkomt, wijst dit op belangrijke aanwijzingen, of aanwijzingen die te maken hebben met de veiligheid van het product.

BELANGRIJK:

alvorens te beginnen met de montage van het product dient u alle aanwijzingen aandachtig door te lezen. Controleer of alle voor de montage benodigde onderdelen in de verpakking aanwezig zijn, en of ze geen defecten vertonen. Verwijder de transparante beschermfolie waar aanwezig. Alvorens de douchecabine definitief te installeren is het raadzaam een voorlopige test te doen door het apparaat een paar minuten te laten werken, om na te gaan of er geen waterlekkages zijn of schade ontstaan is door stoten tijdens het transport of de verplaatsing. Het wordt geadviseerd de installatie over te laten aan gekwalificeerd personeel.

N.B.: De installatie dient te worden uitgevoerd wanneer de vloer en wanden afgewerkt zijn.

Bij elke service-aanvraag dient de faktuur/aankoopbon samen met de installatiehandleiding te worden overlegd.

De afbeeldingen en tekeningen in deze handleiding zijn zuiver als uitleg bedoeld.

De fabrikant behoudt zich het recht voor wijzigingen en veranderingen aan te brengen.

AANDACHT!

De hardheid van het water mag niet meer dan 20° FR (franse graden) bedragen.

De inhoud chloor mag niet meer dan 100 mg per liter bedragen.

Demontage kranen:

Als de kraan niet goed meer functioneert door kalkvorming dienen de onderdelen te worden gedemonteerd (afb. A/B/C...). Het wordt geadviseerd de cartouche in normale schoonmaakazijn te laten weken tot al de kalkaanslag is verdwenen.

Voor de juiste werking van de thermostaatkraan dient men te beschikken over een geiser of boiler die minstens 6/7 liter water per minuut kan afgeven bij een temperatuur van 60/65°C.

REINIGING VAN DE DOUCHECABINE:

ONDERHOUD

De wanden van de cabine zijn vervaardigd met acryl delen, en voor het reinigen dient u dus een vloeibaar, niet schurend, schoonmaakmiddel te gebruiken. Om kalkaanslag te voorkomen is het raadzaam de cabine na gebruik droog te wrijven met een leren zeem of een zachte doek. Eventuele kalkaanslag op de wanden kunt u verwijderen door regelmatig een normale "polish" aan te brengen die ook gebruikt wordt om de carrosserie van auto's te poetsen.

GEBRUIK ABSOLUUT GEEN SCHUURMIDDELEN, ALCOHOL, SCHOONMAAKMIDDELEN OP BASIS VAN ALCOHOL, ACETON OF ANDERE OPLOSSTOFFEN.

STORINGEN:

Controleer voordat u de Technische assistentie belt:

- of de slangen goed zijn aangesloten en niet zijn dubbelgevouwen.
- of het warme en koude water zijn aangesloten op de juiste aansluitingen op de muur.
- of de leidingen doorgespoeld zijn vóór de installatie.
- of de netspanning de stoomcabine naar behoren bereikt, en of het desbetreffende groene lampje op het paneel brandt.

Als de cabine ondanks onze adviezen en uw zorgvuldige

gebruik niet goed zou functioneren, neem dan rechtstreeks contact op met de Technische assistentiedienst bij u in de buurt; de telefoonnummers zijn te vinden in het bijgaande boekje.

VERWERKING ALS AFVAL:

Voor het afdanken van het product of van zijn onderdelen dient u zich te houden aan de lokale voorschriften inzake afvalverwerking. Voor het Italiaanse grondgebied het Wetsbesluit n°22 van 5 februari 1997, voor de andere EEG-landen de richtlijnen 91/156/EEG, 91/689/EEG en 94/62/EEG.



Note:

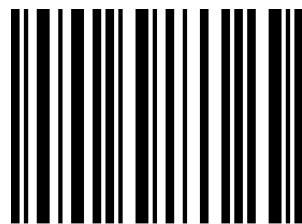

174906